



WORKHORSE

S P R A Y E R S®

Assembly / Operation Instructions / Parts

BK 002

2 Nozzle Quick Attach Boom Kit for ATV Mounting

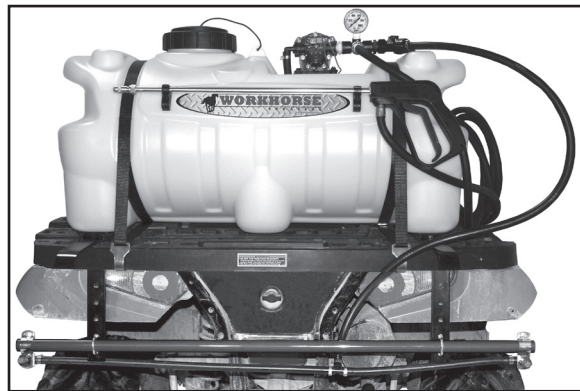
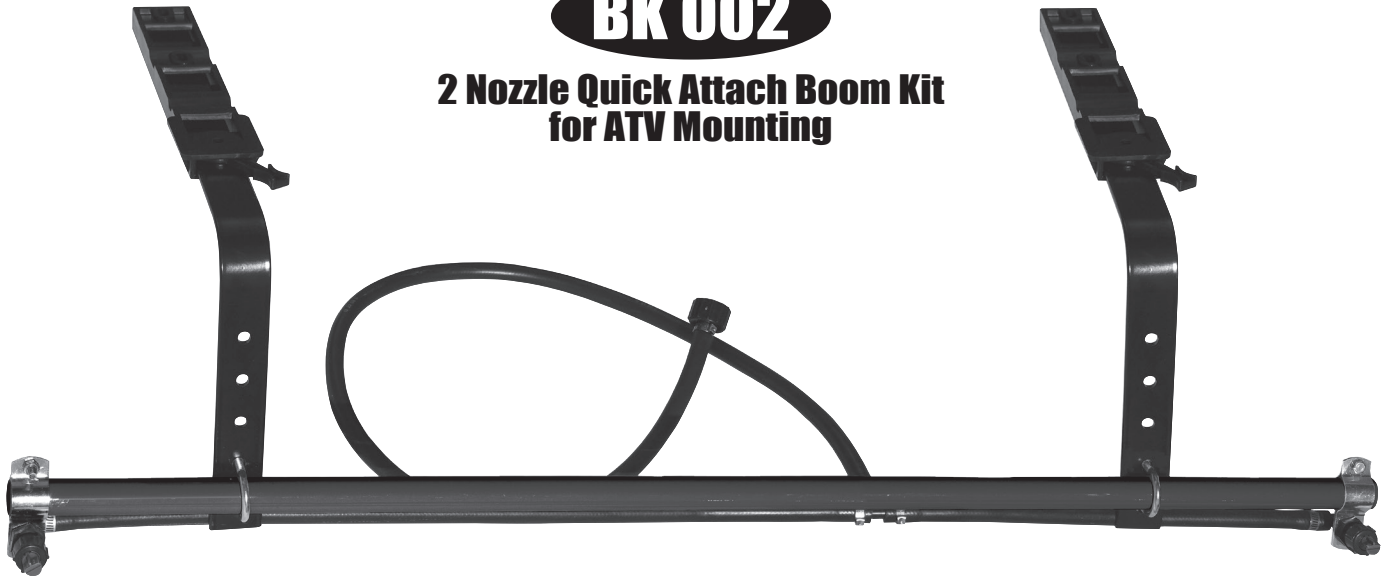

MODEL # BK 002*

DELUXE 2 NOZZLE BOOM KIT

- 2 Nozzle Boom Assembly
- Quick Attach Mounting System
- 80 inch coverage with Check Valve and Filter

* This boom kit is designed to be used with LG15DSS or LG25DSS & attached to an ATV.

— GENERAL INFORMATION

The purpose of this manual is to assist you in assembling, operating and maintaining your ATV Boom Kit. Please read it carefully as it furnishes information which will help you achieve years of dependable trouble-free operation.

— WARRANTY / PARTS / SERVICE

Workhorse products are warranted for one year from the date of purchase against manufacture or workmanship defects for personal or homeowner usage with proof of purchase. Workhorse products are warranted for 90 days for commercial users. Any unauthorized modification of a Workhorse brand sprayer will void warranty.

Your authorized dealer is the best source of replacement parts and service. To obtain prompt, efficient service, always remember to give the following information: 1) Correct part description and part number. 2) Model number and serial number of your sprayer.

Part description and part numbers can be obtained from the illustrated parts list section of this manual.

Whenever you need parts or repair service, contact your distributor / dealer first. For warranty work always take your original sales slip, or other evidence of purchase date, to your distributor / dealer.

— ASSEMBLY INSTRUCTIONS

Tools required:

- Blade Screwdriver
- 3/16" Allen Wrench

— OPERATION

(Recommended to be used with a LG25DSS or similar 2.0 GPM or greater spot sprayer.)

Refer to your original spot sprayer operating instructions.

Pressure may be regulated by opening or closing the valve located on the top of your tank. Refer to your original instructions, or see some common "Valve Operations" illustrated in this manual.

Regularly inspect the suction supply screen on the inside of the tank. Flush with water to clear any accumulated debris.

— CALIBRATION

Chemical product labels may show application rates in gallons per acre, gallons per 1000 square feet, or gallons per 100 square feet. The tip chart for your sprayer shows all three rates for your convenience.

After determining how much mixed solution you are going to spray for your job, select the spraying pressure (PSI) and spraying speed (MPH) needed.

Current weather and terrain conditions must be considered when setting up the sprayer. Do not spray on windy days (over 11 MPH), and protective clothing must be worn with some products.

Be sure to read the chemical label carefully.

For the best spray pattern coverage, the nozzles may be rotated rearward 15°.

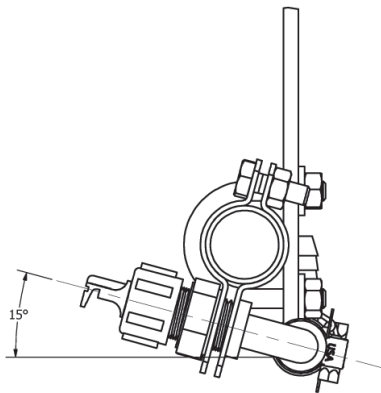

To determine the ground speed of your sprayer, measure and mark driving distances of 100, 200, or 300 feet. Our speed chart indicates the number of seconds needed to travel these distances. Set your throttle, and with a rolling start, drive the measured distance of your choice. Adjust your throttle until you can match the number of driving seconds needed. Mark the throttle setting and note the gear range so you can use them while spraying.

Add water and chemicals in the proper amounts in the spray tank and drive to your starting point. When you are ready to spray, turn your boom control valve to the "ON" position. Once the pump is turned on, the unit will begin spraying. The system pressure will decrease slightly when you see solution flowing from the spray nozzles. This is normal, the pressure will return as before when you turn the control valve to the "OFF" position.

You will find optimal spraying in the 20 to 30 PSI range.

— AFTER SPRAYING

After use, fill the sprayer part way with water. Start the sprayer and allow clear water to be pumped through the plumbing system and out through the spray nozzles.

Refill the tank about half full with plain water and use a chemical neutralizer such as Nutra-Sol® or equivalent and repeat cleaning instructions. Flush the entire sprayer with the neutralizing agent. Follow the chemical manufacturer's disposal instructions of all wash or rinsing water.

Remove tips and screens from the boom. Wash tips thoroughly with water or cleaning solution (appropriate for chemical used). Blow out orifice, clean and dry. If orifice remains clogged clean it with a fine bristle (not wire) brush, or with a toothpick. Do not damage the orifice. Water rinse and dry tips before storing.

— WINTER STORAGE

Drain all water and chemical out of sprayer, paying special attention to pump and valves. These items are especially prone to damage from chemicals and freezing weather.

The sprayer should be winterized before storage by pumping a solution of RV antifreeze through the entire plumbing. Proper care and maintenance will prolong the life of the sprayer.

— TIP CHART

| Tip No. | Spray Height | Pressure (PSI) | Capacity (GPM) | GALLONS PER ACRE - BASED ON WATER | | | | | | |
|---------|--------------|----------------|----------------|---|-------|-------|-------|-------|---------|--------|
| | | | | 1 MPH | 2 MPH | 3 MPH | 4 MPH | 5 MPH | 7.5 MPH | 10 MPH |
| 3 | 18" | 10.0 | 0.30 | 44.0 | 22.0 | 14.9 | 11.1 | 08.9 | 05.9 | 4.50 |
| | | 20.0 | 0.42 | 63.0 | 31.5 | 20.9 | 15.7 | 12.6 | 08.4 | 6.30 |
| | | 30.0 | 0.52 | 76.0 | 38.0 | 26.0 | 19.3 | 15.4 | 10.3 | 7.70 |
| | | 40.0 | 0.60 | 90.0 | 45.0 | 30.0 | 22.0 | 17.8 | 11.8 | 8.90 |
| Tip No. | Spray Height | Pressure (PSI) | Capacity (GPM) | GALLONS PER 1000 SQ. FT. - BASED ON WATER | | | | | | |
| | | | | 1 MPH | 2 MPH | 3 MPH | 4 MPH | 5 MPH | 7.5 MPH | 10 MPH |
| 3 | 18" | 10.0 | 0.30 | 1.01 | 0.50 | .340 | .254 | .204 | .135 | .103 |
| | | 20.0 | 0.42 | 1.40 | 0.72 | .480 | .360 | .290 | .190 | .140 |
| | | 30.0 | 0.52 | 1.74 | 0.87 | .596 | .440 | .350 | .236 | .176 |
| | | 40.0 | 0.60 | 2.06 | 1.00 | .688 | .500 | .408 | .270 | .200 |
| Tip No. | Spray Height | Pressure (PSI) | Capacity (GPM) | GALLONS PER 100 SQ. FT. - BASED ON WATER | | | | | | |
| | | | | 1 MPH | 2 MPH | 3 MPH | 4 MPH | 5 MPH | 7.5 MPH | 10 MPH |
| 3 | 18" | 10.0 | 0.30 | .100 | .050 | .034 | .025 | .020 | .013 | .010 |
| | | 20.0 | 0.42 | .140 | .072 | .048 | .036 | .029 | .019 | .014 |
| | | 30.0 | 0.52 | .174 | .087 | .059 | .044 | .035 | .0236 | .017 |
| | | 40.0 | 0.60 | .206 | .100 | .068 | .050 | .040 | .027 | .020 |

— VALVE OPERATION

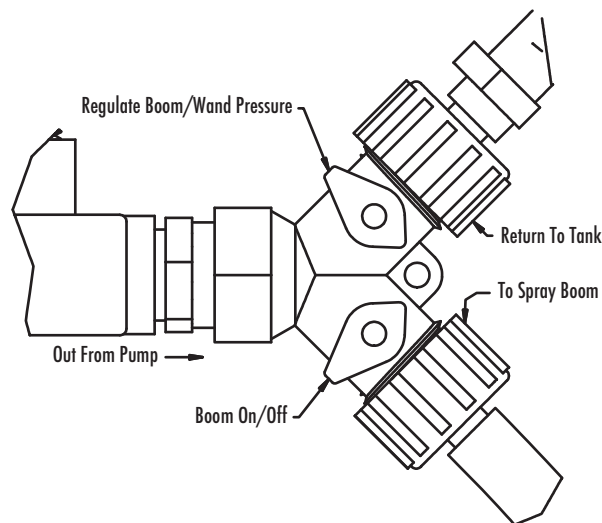
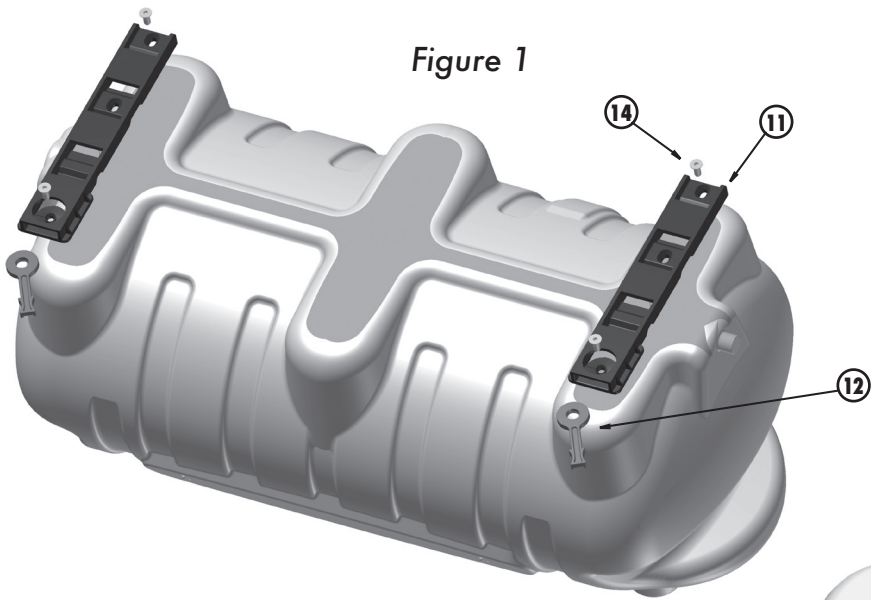

Figure 1



Boom Kit Assembly:

Figure 1 –
1. Attach ATV Mount (#11) and Helix Lever (#12) to bottom of tank with Screws (#14) as illustrated.

Figure 2 –
2. Insert Angle Brackets (#13) into ATV Mounts as illustrated.

Figure 3 –
3. Attach Spray Boom (#2) to Angle Brackets with U-Bolts (#1) as illustrated.
4. Install 2 Boom Clamps (#3) on ends of Spray Boom (#2) and tighten screws (screws should be on the top of the Spray Boom).
5. Install Worm Clamp (#10) over tubing and press tubing onto fittings (#4) then tighten clamps.
6. Install 2 fittings (#4) thru Boom Clamps (#3) and install Nuts (#6) (Do not over – tighten nuts).
7. Insert 2 Check Valve / Strainers (#7) in fittings (#4).
8. Insert 2 Spray Tips (#8) in Nuts (#5) and screw nuts onto fittings (#4) (assure that tips are oriented with spray pattern downward to assure proper spray pattern)

Figure 2

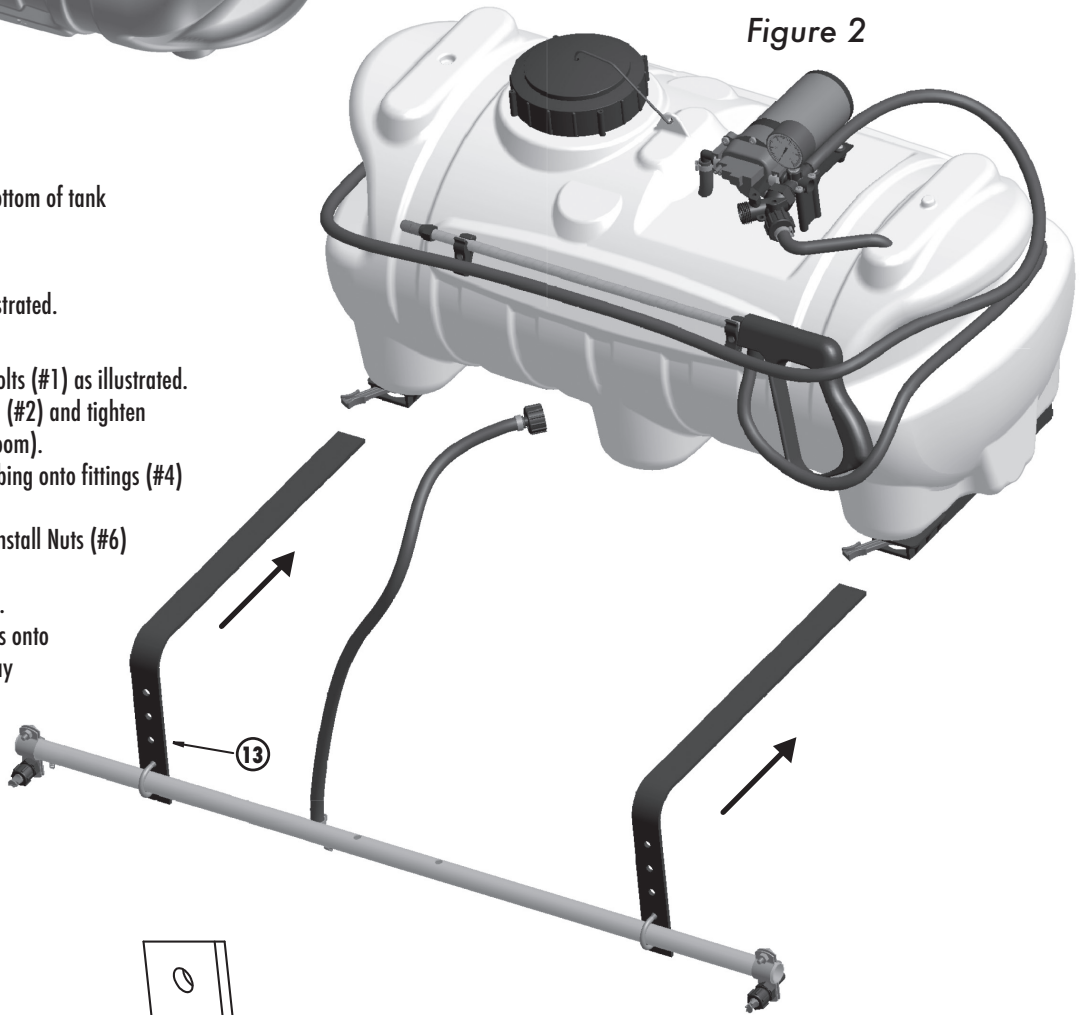
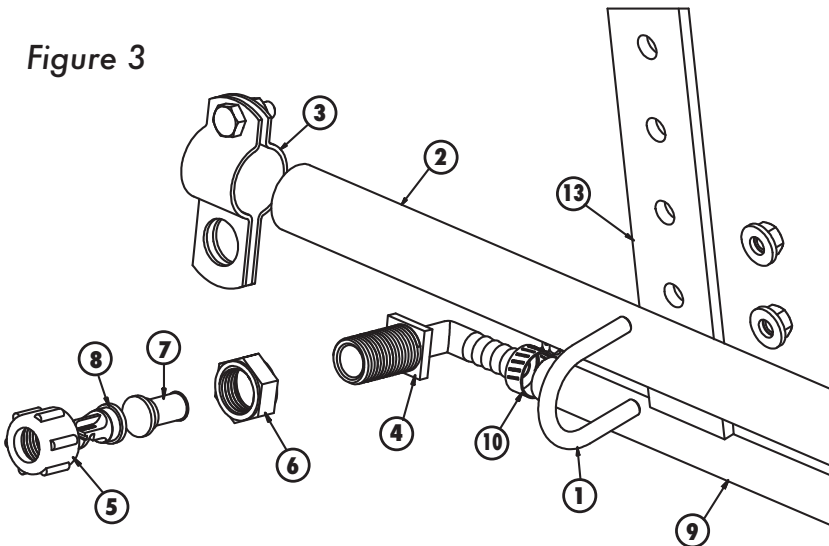
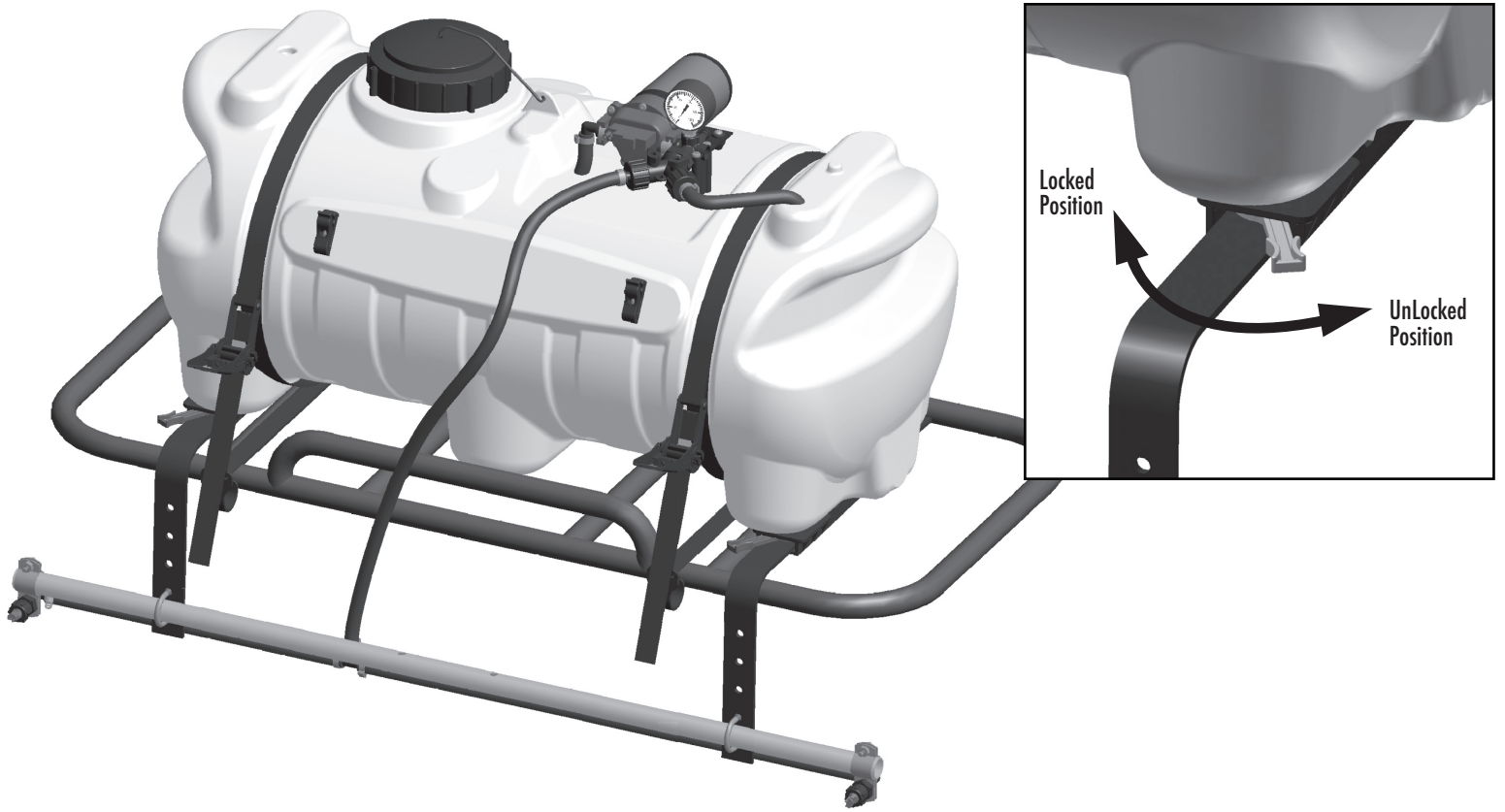

Figure 3



| PARTS LIST | | | |
|------------|-----|---------|---|
| ITEM | QTY | STOCK # | DESCRIPTION |
| 1 | 2 | 600169 | 1/4" U-Bolt with Nuts |
| 2 | 1 | 630111 | Spray Boom |
| 3 | 2 | 600113 | B 11 - 3/4" R Boom Clamp Assembly |
| 4 | 2 | 600112 | NTL 38 P Fitting |
| 5 | 2 | 600119 | 8027 P Nut |
| 6 | 2 | 600116 | N 1116 P Nut |
| 7 | 2 | 600117 | Check Valve / Strainer |
| 8 | 2 | 600118 | Spray Tip |
| 9 | 1 | 600115 | Boom Hose Assembly |
| 10 | 2 | 600120 | 5/8" Hose Clamp |
| 11 | 2 | 600189 | ATV Mount |
| 12 | 2 | 600190 | Helix Lever |
| 13 | 2 | 600191 | Angle Bracket |
| 14 | 4 | 600188 | 5/16 - 18 x 3/4" FLT HD Socket Head Cap Screw |



WARNING:
This product can expose you to chemicals including DEHP, known to the State of California to cause birth defects or other reproductive harm.