



WORKHORSE

S P R A Y E R S

Assembly / Operation Instructions / Parts

25 GALLON TRAILER SPRAYER



*** This sprayer is designed to be towed behind a garden tractor.**

MODELS #LG25STS & LG25DTS

25 GALLON TRAILER SPRAYER

- Compact Trailer and Tank
- Polyethylene Tank
- 4.10/3.50 x 6 Pneumatic Tires
- 12 Volt Diaphragm Pump
- 2.2 G.P.M.
- Lever Handgun
- 15 Ft. of 3/8" Hose (Handgun)
- Pressure Gauge
- Adjustable Pressure Range (0-60 PSI Max.)
- Break Away Boom-2 nozzles, 80" Coverage with check valve and filter

— GENERAL INFORMATION

The purpose of this manual is to assist you in assembling, operating and maintaining your lawn and garden sprayer. Please read it carefully as it furnishes information which will help you achieve years of dependable trouble-free operation.

— WARRANTY / PARTS / SERVICE

Workhorse products are warranted for one year from the date of purchase against manufacture or workmanship defects for personal or homeowner usage with proof of purchase. Workhorse products are warranted for 90 days for commercial users. Any unauthorized modification of a Workhorse brand sprayer will void warranty.

Your authorized dealer is the best source of replacement parts and service. To obtain prompt, efficient service, always remember to give the following information: 1) Correct part description and part number. 2) Model number and serial number of your sprayer.

Part description and part numbers can be obtained from the illustrated parts list section of this manual.

Whenever you need parts or repair service, contact your distributor / dealer first. For warranty work always take your original sales slip, or other evidence of purchase date, to your distributor / dealer.

WARNING: Some chemicals will damage the pump valves if allowed to soak untreated for a long period of time. Always flush the pump with water after use. Do not allow chemicals to sit in pump for extended times of idleness. Follow chemical manufacturers instructions on disposal of all waste water from the sprayer.

— ASSEMBLY INSTRUCTIONS

Tools required:

2 — 7/16" End Wrenches	1 — Pliers
1 — 9/16" End Wrench	1 — Thread Sealant
1 — 1/2" End Wrench	1 — Blade Screwdriver
1 — 3/4" End Wrench	

— OPERATION

The pumping system draws solution from the tank, through the strainer and to the pump. The pump forces the solution under pressure to the boom nozzles and spray wand.

The pump has a pressure switch which will shut the pump off when it reaches 60 PSI.

Pressure may be regulated by opening or closing the valve located on the top of the tank. See "Valve Operation" illustrated in this manual.

The nozzles on the boom will spray an 80 inch wide swath. Check the nozzle spray pattern by spraying water on a concrete surface.

Regularly inspect the suction supply screen on the inside of the tank. Flush with water to clear any accumulated debris.

— TIP CHARTS

Tip No.	Spray Height	Pressure (PSI)	Capacity (GPM)	GALLONS PER ACRE - BASED ON WATER							
				1 MPH	2 MPH	3 MPH	4 MPH	5 MPH	7.5 MPH	10 MPH	
3	18"	10.0	0.30	44.0	22.0	14.9	11.1	08.9	05.9	4.50	
		20.0	0.42	63.0	31.5	20.9	15.7	12.6	08.4	6.30	
		30.0	0.52	76.0	38.0	26.0	19.3	15.4	10.3	7.70	
		40.0	0.60	90.0	45.0	30.0	22.0	17.8	11.8	8.90	

Tip No.	Spray Height	Pressure (PSI)	Capacity (GPM)	GALLONS PER 1000 SQ. FT. - BASED ON WATER							
				1 MPH	2 MPH	3 MPH	4 MPH	5 MPH	7.5 MPH	10 MPH	
3	18"	10.0	0.30	1.01	0.50	.340	.254	.204	.135	.103	
		20.0	0.42	1.40	0.72	.480	.360	.290	.190	.140	
		30.0	0.52	1.74	0.87	.596	.440	.350	.236	.176	
		40.0	0.60	2.06	1.00	.688	.500	.408	.270	.200	

Tip No.	Spray Height	Pressure (PSI)	Capacity (GPM)	GALLONS PER 100 SQ. FT. - BASED ON WATER							
				1 MPH	2 MPH	3 MPH	4 MPH	5 MPH	7.5 MPH	10 MPH	
3	18"	10.0	0.30	.100	.050	.034	.025	.020	.013	.010	
		20.0	0.42	.140	.072	.048	.036	.029	.019	.014	
		30.0	0.52	.174	.087	.059	.044	.035	.0236	.017	
		40.0	0.60	.206	.100	.068	.050	.040	.027	.020	

Tip No.	Pressure (PSI)	Capacity (GPM)	GALLONS PER ACRE BASE ON WATER-40" SPACING			
			5 MPH 440 FPM	6 MPH 528 FPM	7 MPH 616 FPM	8 MPH 704 FPM
5	10	0.50	14.9	12.4	10.6	9.3
	20	0.71	21.0	17.6	15.1	13.2
	30	0.87	26.0	22.0	18.5	16.1
	40	1.00	30.0	25.0	21.0	18.6

Most chemical labels indicate a chemical application rate in 1,000 sq. ft.; if the rate on the label is indicated as a rate per acre, divide the per acre rate by 43.56 to convert to a rate per 1,000 sq. ft.

1 Acre = 43,560 sq. ft.

1 gallon per 1,000 sq. ft. = 43.56 gallons per acre

1 fl. Oz. = 2 tablespoons

1 cup = 8 fl. Oz.

1 pint = 2 cups = 16 fl. Oz.

1 quart = 2 pints = 32 fl. Oz.

1 gallon = 4 quarts = 8 pints = 128 fl. oz.

— SPEED CHART

Speed in MPH (Miles Per Hour)	Time Required in Seconds to Travel a distance of:		
	100 ft.	200 ft.	300 ft.
1.0	68.0	136	205
2.0	34.0	68	102
3.0	23.0	45	68
4.0	17.0	34	51
5.0	14.0	27	41
6.0	11.0	23	34
7.0	9.7	19	29
8.0	8.5	17	26
9.0	7.6	15	23
10.0	6.8	14	20

— CALIBRATION

Chemical labels may show application rates in gallons per acre, gallons per 1000 square feet or gallons per 100 square feet. You will note that the tip chart shows all three of these rating systems.

Once you know how much you are going to spray then determine (from the tip chart) the spraying pressure (PSI), and the spraying speed (MPH).

Conditions of weather and terrain must be considered when setting the sprayer. Do not spray on windy days. Protective clothing must be worn in some cases. **Be sure to read the chemical label carefully.**

Determining the proper speed of the tractor can be done by marking off 100, 200 and 300 feet. The speed chart indicates the number of seconds it takes to travel the distances. Set the throttle and with a running start travel the distances. Adjust the throttle until you travel the distances in the number of seconds indicated by the speed chart. Once you have reached the throttle setting needed, mark the throttle location so you can stop and go again (returning to the same speed).

Add water and proper amount of chemical to tank and drive to the starting place for spraying.

When you are ready to spray, turn the boom valve to the "on" position. This will start solution spraying from the tips once the pump is turned on. The pressure will decrease slightly when the boom is spraying.

— AFTER SPRAYING

After use, fill the sprayer part way with water. Start the sprayer and allow clear water to be pumped through the plumbing system and out through the spray nozzles.

Refill the tank about half full with plain water and use a chemical neutralizer such as Nutra-Sol® or equivalent and repeat cleaning instructions. Flush the entire sprayer with the neutralizing agent. Follow the chemical manufacturer's disposal instructions of all wash or rinsing water.

Remove tips and screens from the boom. Wash tips thoroughly with water or cleaning solution (appropriate for chemical used). Blow out orifice, clean and dry. If orifice remains clogged clean it with a fine bristle (not wire) brush, or with a tooth pick. Do not damage the orifice. Water rinse and dry tips before storing.

— WINTER STORAGE

Drain all water and chemical out of sprayer, paying special attention to pump and valves. These items are especially prone to damage from chemicals and freezing weather.

The sprayer should be winterized before storage by pumping a solution of RV antifreeze through the entire plumbing. Proper care and maintenance will prolong the life of the sprayer.

WARNING:

This product can expose you to chemicals including DEHP, known to the State of California to cause birth defects or other reproductive harm.

– TANK ASSEMBLY

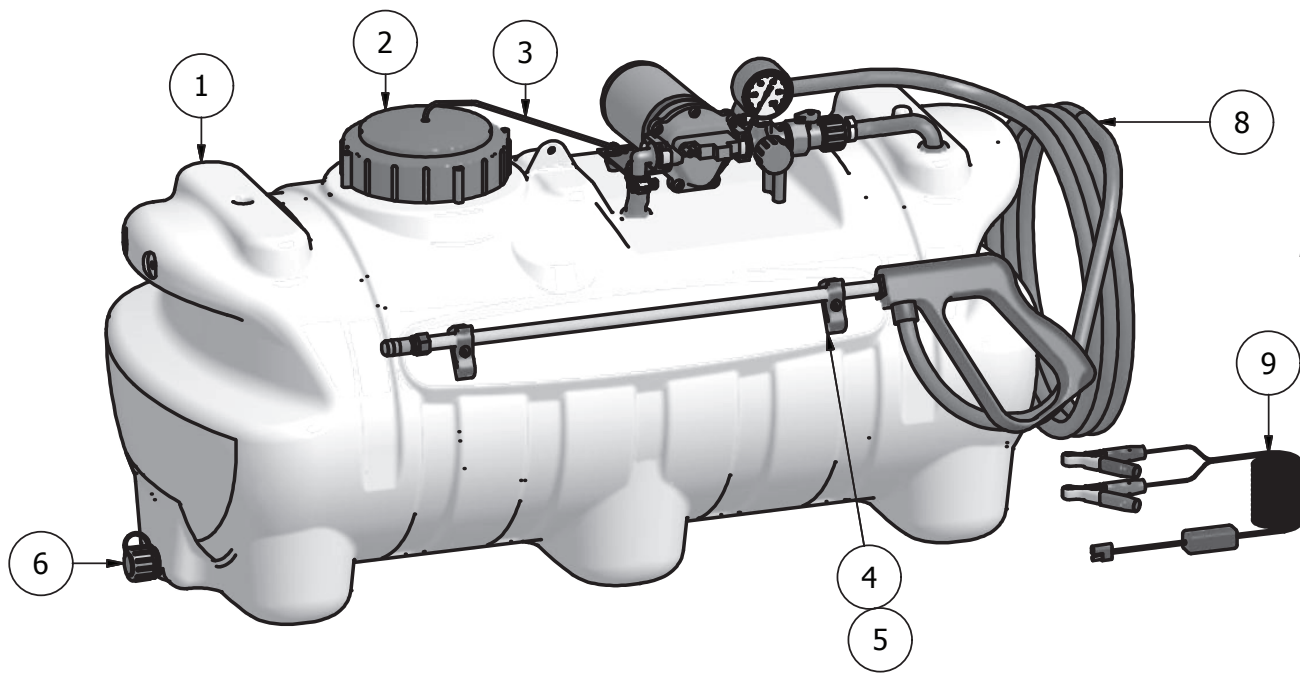

LG25DTS

PARTS LIST			
ITEM	QTY	PART NUMBER	DESCRIPTION
1	1	600132	25 Gallon Tank
2	1	600133	Tank Lid
3	1	600134	Tank Lid Tether
4	2	600151	Spray Wand Clip
5	2	600152	10-24 x 3/8" Screw
6	1	600298	Drain Cap Assembly
7	1	600261	Economy Wand and Hose Assembly
8	1	600156	Deluxe Wand and Hose Assembly
9	1	600153	Lead Wire Assy. w/ Switch (96")

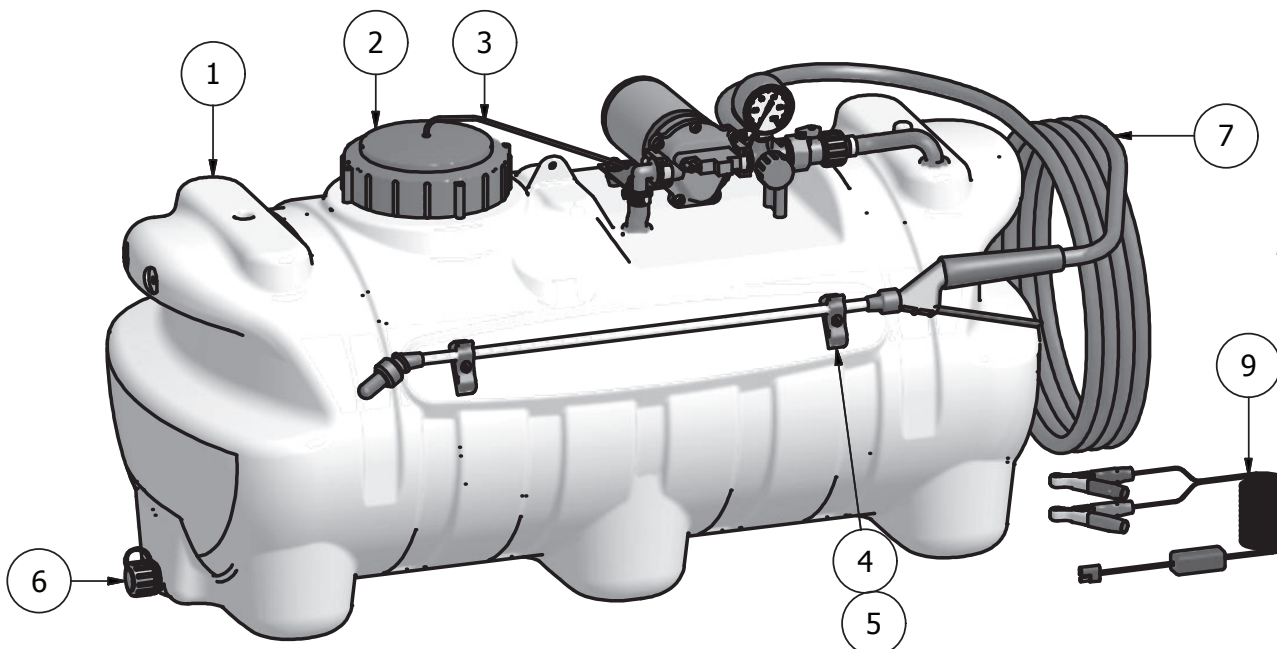

LG25STS

— TRAILER ASSEMBLY Instruction #1

PARTS LIST		DESCRIPTION
ITEM	QTY	PART NUMBER
1	1	630184
2	2	600101
3	1	600244
4	2	600104
5	2	600245
6	2	630103
7	6	600109
8	2	600106
9	2	600107

Assembly Instructions

1.0-- Assemble the tank and trailer frame as illustrated using hardware shown. Note the orientation of the Frame Member items as their orientation is essential for proper assembly. (The Stop Pad on the Frame Tube should go against the tank)

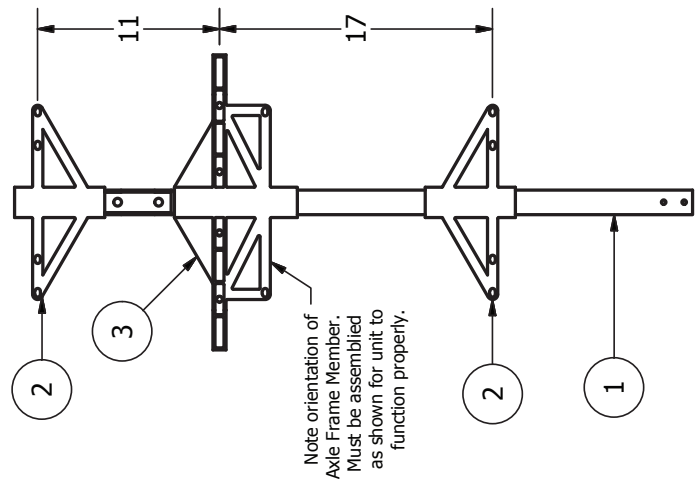
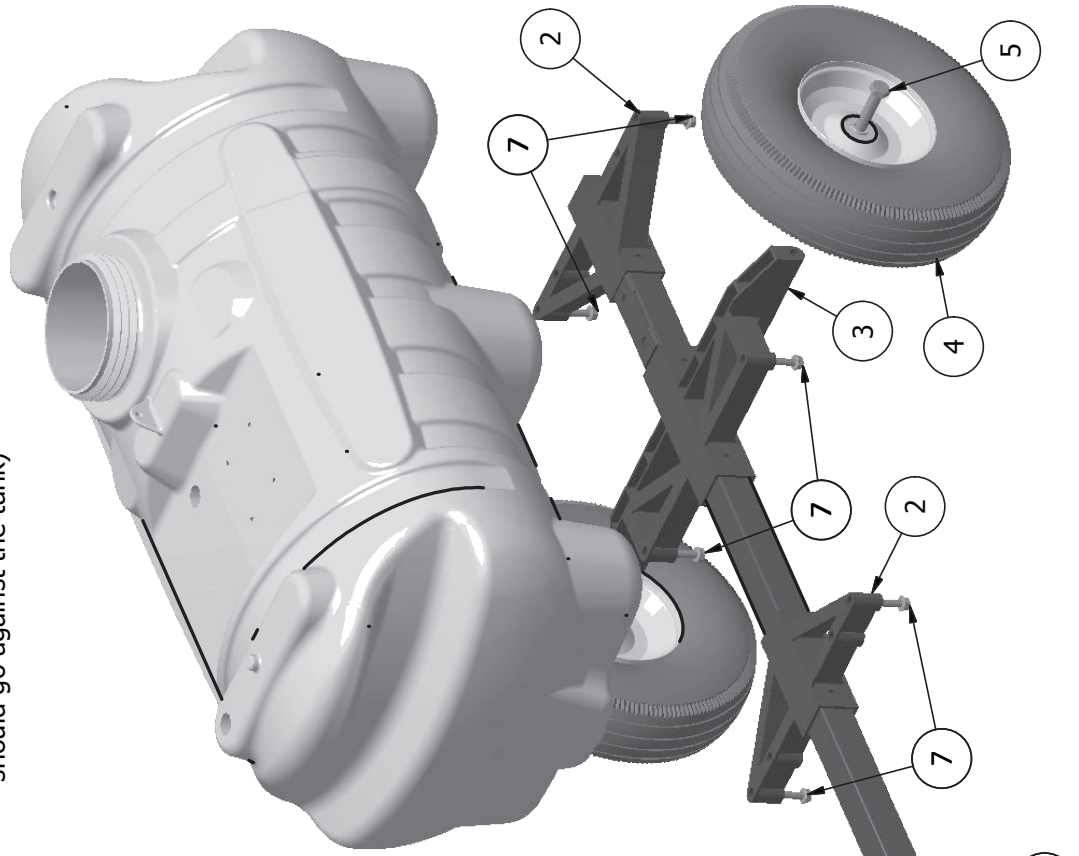

To Order Replacement Parts: 1-888-433-6631

— SPRAY BOOM ASSEMBLY

Instruction #2

- 2.0 Install Spray Boom Bracket to rear of tank using (2) 5/16-18 x 3/4" Bolts
- 2.1 Insert Boom Supply Hose Assembly thru Spray Boom Bracket as illustrated
- 2.2 Snap Spray Boom into Bracket aligning locator holes in boom and bracket
- 2.3 Install (2) Boom Clamps on end of spray Boom and Tighten Screws (screws should be at top of spray boom)
- 2.4 Install Hose Clamp over tubing and press tubing onto NTL 38 P fittings then tighten Hose Clamps
- 2.5 Install NTL 38 P fittings thru Boom Clamps and tighten N1116 P Nuts as shown
- 2.6 Insert check valves into NTL 38 P Fittings
- 2.7 Insert Spray Tips into 8027 P Nuts and screw nuts onto NTL 38 P Fittings.

PARTS LIST			
ITEM	QTY	PART NUMBER	DESCRIPTION
1	1	630111	Spray Boom
2	1	600110	25 Gal Spray Boom Bracket
3	2	600113	B 11-34 R
4	2	600112	NTL38 P Fitting
5	2	600116	N1116 P Nut
6	2	600117	Check Valve / Strainer
7	2	600118	FT Spray Tip
8	2	600119	8027 P Nut
9	2	600120	5/8" Hose Clamp
10	1	600209	Boom Hose Assembly
11	2	600114	5/16-18 x 3/4" Bolt

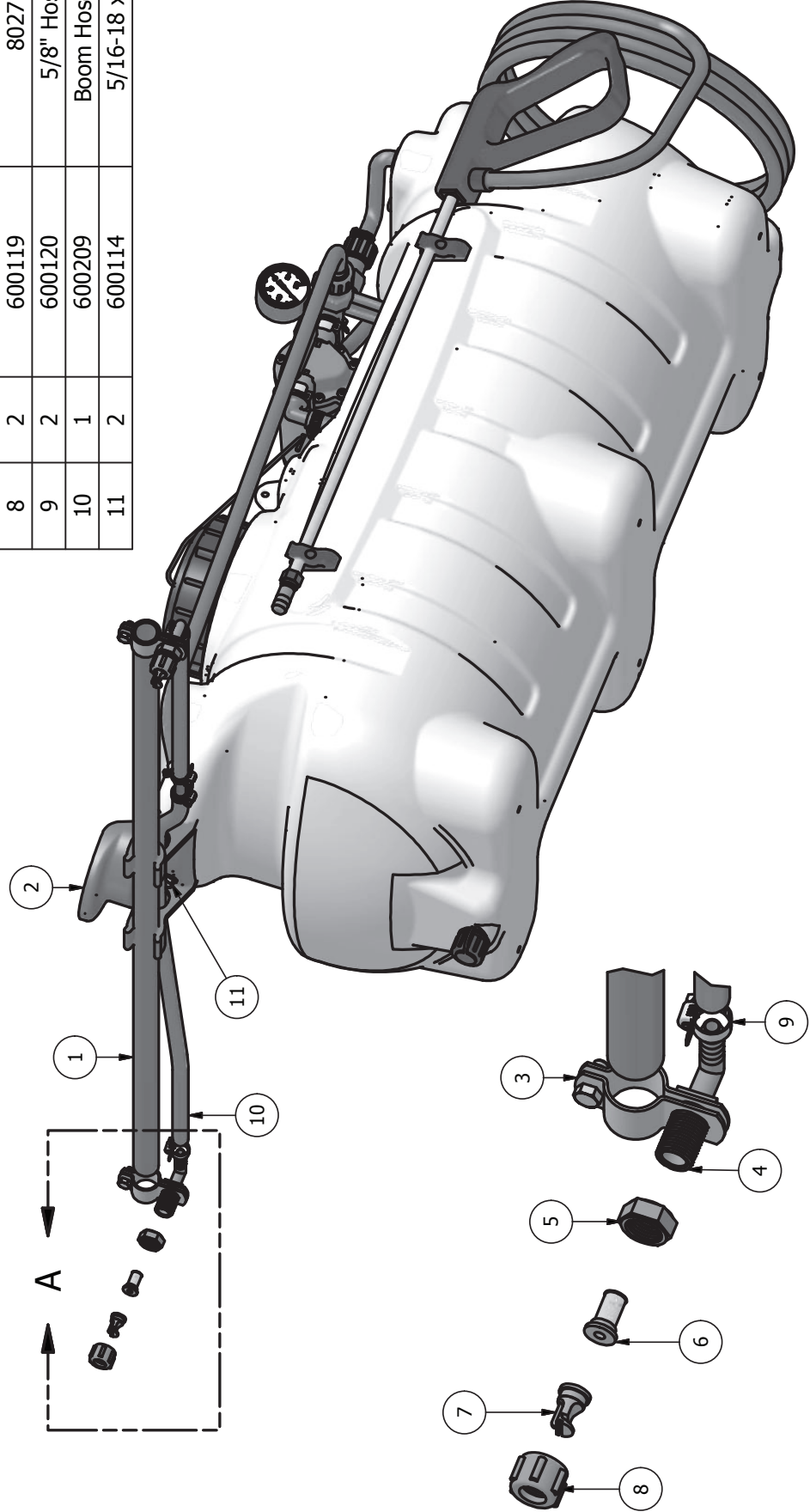

– PUMP & VALVE ASSEMBLY

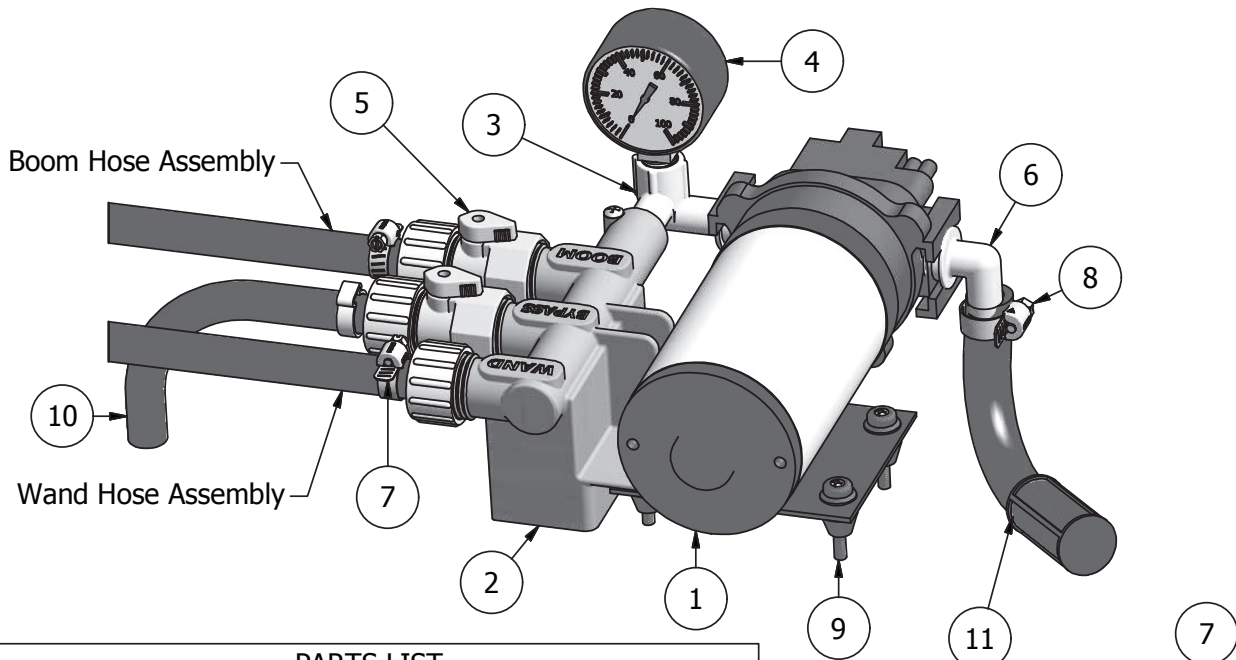

PARTS LIST			
ITEM	QTY	PART NUMBER	DESCRIPTION
1	1	640451	2.2 GPM Pump*
1	1	630201	4.0 GPM Pump*
1	1	630031	5.0 GPM Pump*
2	1	600289	Manifold Body
3	1	600291	Elbow (2.2 pumps)
3	1	600292	Elbow (4.0 & 5.0 pumps)
4	1	600129	Gauge 0-100 PSI
5	2	600216	Inline Valve
6	1	600287	QD EL 12
7	2	600120	5/8" Hose Clamp
8	1	600288	1/2" Hose Clamp
9	4	600130	10-24 x 1.25 Screw
10	1	600213	Relief Hose Assembly
11	3	600315	Suction Hose Assembly
12	1	600298	Cap Assembly (not shown)

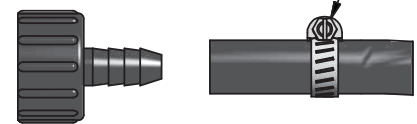

Install Wand Hose Assembly onto Swivel Barb Assembly, by placing a Hose Clamp over the open end of the hose on the Wand Hose Assembly. Then pressing the open end of the hose onto the Swivel Barb Assembly like shown. Secure in place by tightening the Hose Clamp as shown.

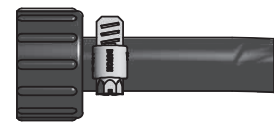

*Pump included depends upon model purchased.

The Lever adjusts the system pressure by relieving liquid back to the tank. Adjusting this lever will increase or decrease pressure to both the spray wand and the spray boom.

The lever turns the spray boom on and off

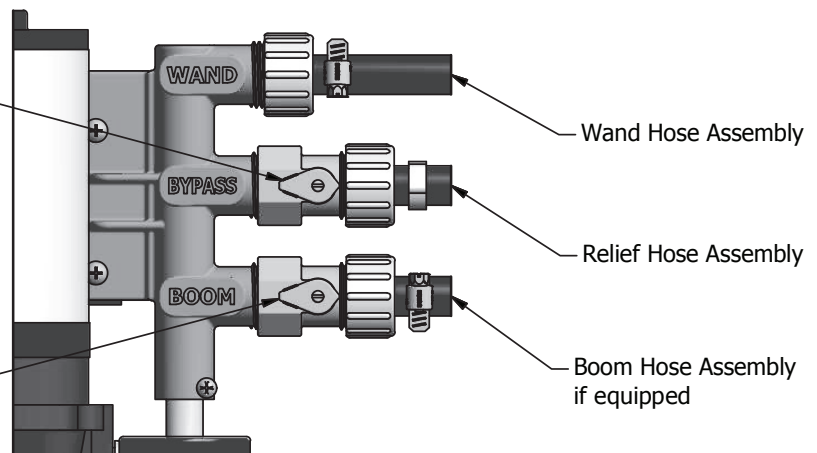

PowerFLO™ 7800 Series

12 Volt DC Motor-Driven Diaphragm Pumps

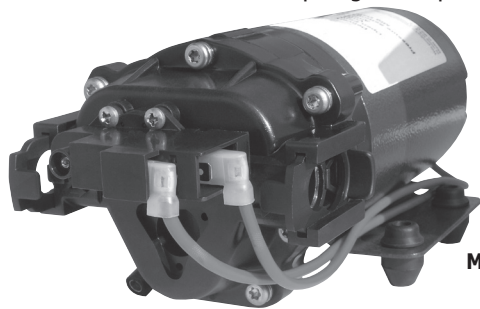

Model: 7802: 2.2 GPM

Specifications —

Motor:

Type: 12 VDC, permanent magnet, totally enclosed, non-ventilated

Leads: 16 AWG, 12" long

Temperature Limits: Motor is not equipped with thermal protection. For user safety, optimal performance, and maximum motor life, the motor surface temperature should not exceed 150°F (66°C).

Pump:

Type: 3 chamber positive displacement diaphragm pump, self priming, capable of being run dry, demand or bypass model.

Certifications: NSF Standard 58

Liquid Temperature: 140°F (60°C) Max.

Priming Capabilities: 14 feet (4 m)

Max Pressure: 60 PSI

Inlet/Outlet Ports: 7802: Quick Attach

Materials of Construction:

Housing: Polypropylene

Diaphragm: Santoprene

Valves: Viton

Fasteners: Stainless steel

Weight: 6 lbs (2.7 kg)

Installation and Operation Precautions —

1. The pump is equipped with a pressure sensing demand switch that controls the maximum operating pressure.
2. In addition, never subject the pump to pressures above 125 PSI (8.5 bars).
3. As long as there is inlet water pressure, the pump will not stop forward flow of water even if the motor is turned off. Be sure the system has positive means of shutting off water supply.
4. Do not operate pump in an explosive environment. Arcing from the motor brushes, switch or excessive heat from an improperly cycled motor may cause an explosion.
5. Do not locate the pump motor near low temperature plastics or combustible material. The surface temperature of the motor may exceed 250°F (120°C).
6. Do not pump gasoline or other flammable liquids. Pump head materials are designed for use with water only. Do not use with petroleum products.
7. Do not assume fluid compatibility. If the fluid is improperly matched to the pumps' elastomers, a leak may occur.
8. To prevent electrical shock, disconnect power before initiating any work. In the case of pump failure, the motor housing and/or pump fluid may carry high voltage to components normally considered safe. Therefore, always consider electrical shock hazard when working with and handling electrical equipment. If uncertain, consult an electrician. Electrical wiring should only be done by a qualified electrician per local and state electrical codes.

Spray & Pump FAQs —

- Why does the pump not run all the time? This is a demand pump and only runs with flow; spray wand, by-pass, spray tips or leak in system
- Why does the pump surge while using the spray wand? Low flow may cause the pump to surge (or cycle). This could happen when the spray wand is adjusted for a small or fine spray pattern. To overcome, slightly open the by-pass valve.
- How do I adjust the pressure? Pressure should be adjusted by regulating the by-pass valve (slightly opening or closing).
- What is the optimal operating pressure? 40 PSI - This can be accomplished by turning on the pump and adjusting the bypass valve until the gauge reads 40 PSI (or slightly higher). The pump will run continuously. Ensure that the boom and/or handgun is not spraying while you set the pressure. The pressure will drop slightly when the boom and/or handgun is operated.
- What pressure should the pressure gauge read? Please refer to the operation instructions for boom operating pressures, varying boom pressures can be achieved by regulating or adjusting the by-pass valve. Typically the spray wand will be operated between 20 and 40 PSI.
- My pump quit and will not restart - what should I check? Check all electrical connections. Ensure switch is in the on position. Check in-line fuse and/or fuse in car adapter end. Ensure correct voltage +/- 10%. 12-13 volt
- Low flow or no flow at all - what should I check? Check for a clogged suction hose and/or suction strainer. Often you will need to clean the suction strainer. Check for proper voltage.
- Is there a fuse for the sprayer? Yes, either an in-line fuse, a fuse located in the car adapter housing or both.
- What is the range of the spray wand? 35 feet max
- How should I clean the tank after use? Tank should be cleaned with Nutrasol® or similar tank cleaning agent, and then rinsed with water.
- Is there an adjustment screw on the pump to adjust pressure? Yes, please refer to the operation instructions, "Adjusting the Pressure Switch".
- How do I remove / replace fuse? Unscrew in-line fuse connector, or unscrew the car adapter housing.
- Each time I turn on the pump my fuse blows. 1) Excessive voltage. 2) Improper adjustment of the pressure switch. 3) Damaged wiring harness.
- What is the warranty (time duration) on pump, tank, and accessories? 2 years as stated in operation instructions.
- Pressure gauge reads 85 -90 psi before shutting off - should pump shut off at 60 psi? Pump 7802 2.2 GPM comes preset from the factory to shut off at 60 PSI. Should this vary please see, "Adjusting the Pressure Switch" in the operation manual. Turn on pump and hold spray wand open, slowly adjust until the pump shuts off at 60 PSI.
- Pump continues to run and surge when not spraying. Ensure the by-pass is completely closed and your system has no leaks. Check by-pass hose to ensure no fluid is passing through the valve while in the closed position. If so replace valve.

WARNING - Ensure the wiring harness does not become pinched or damaged in any way. This may damage the pump or cause the wiring harness to overheat, resulting in a melt down or fire.

Pressure Sensing Demand Switch —

12/16

The PowerFLO Series 7800 pump is controlled by a built-in pressure sensing demand switch. When a faucet or valve is opened down stream of the pump, line pressure drops thus starting the pump automatically. Conversely, when the valve shuts, the line pressure increases turning the pump off automatically. The pressure switch actuates in response to the pump outlet pressure at a predetermined and preset pressure. The pump label indicates the predetermined ON and OFF pressures. Typically, the OFF pressure is accurately set at the Factory and the ON pressure is within an allowable range below that value. In response to the characteristics of the system in which the pump is installed, the flexibility and length of the tubing, the faucet or valves and the duration that they are open; these pressure settings may vary. Therefore, variation in pressure setting is expected with use and over time.

Adjusting the Pressure Switch:

Should the pressure switch OFF setting vary with use and time to an unsuitable value, it may be adjusted for optimum performance. Turn the setscrew clockwise to increase the OFF pressure setting and counter clockwise to decrease. The screw should not be adjusted more than one half turn without consulting the Factory. Excessive adjustment of the pressure switch could cause low system pressure, rapid cycling ON/OFF operation, and reduced pump and motor life. Damage may occur. The Warranty does not cover improper adjustment of the pressure switch.

Servicing —

Every Year: Check system against operating standards.

Every 2-3 Years: We recommend replacing the diaphragm and checking against operating standards.

* Important return safety instructions:

When you return your pump for warranty or repair, you must always do the following:

1. Flush chemical residue from the pump (best done in the field).
2. Tag pump with type of chemicals having been sprayed.
3. Include complete description of operation problem, such as how pump was used, symptoms of malfunction, etc. Since pumps can contain residues of toxic chemicals these steps are necessary to protect all the people who handle return shipments, and to help pinpoint the reason for the breakdown.

Troubleshooting — Problem/Causes and Remedies:

Pump will not Start --- Check:

- Correct voltage ($\pm 10\%$) and electrical connections
- Fuse or breaker
- Pressure switch operation and correct voltage at switch
- Rectifier or motor for open or grounded circuit
- Locked drive assembly

Pump will not Prime (No discharge with motor running) --- Check:

- Debris in strainer
- Restriction (kinks) in inlet/outlet tubes
- Debris or swelling in inlet/outlet valves

Pump will not Shut Off (Output line closed and no leaks) --- Check:

- Air trapped in outlet line or pump head
- Correct voltage to pump
- Debris in pump inlet/outlet valves
- Loose drive assembly or pump head screws
- Pressure switch operations/adjustments

Leaks from Pump Head or Switch --- Check:

- Loose screws at switch or pump head
- Switch diaphragm ruptured or pinched
- Punctured diaphragm if fluid is present