

WORKHORSE

S P R A Y E R S

a Division of Green Leaf, Inc®

Assembly / Operation Instructions / Parts

40 & 60 GALLON

DTS - UTL Series DELUXE SPRAYERS

Polyethylene Tank

12 Volt Diaphragm Pump

2.2 or 4.0 G.P.M.

Deluxe Pistol Grip Handgun with Adjustable Brass Tip

25 Ft. of 3/8" Hose (handgun)

Pressure Gauge

Adjustable Pressure range (0-60 PSI Max.)



UTL Series



DTS Series

— GENERAL INFORMATION

The purpose of this manual is to assist you in assembling, operating and maintaining your lawn and garden sprayer. Please read it carefully as it furnishes information which will help you achieve years of dependable trouble-free operation.

— ASSEMBLY

Tools required:

- 1 - 7/16" End Wrench
- 2 - 1/2" End Wrenches
- 1 - Phillips Screwdriver
- 1 - Pliers
- 1 - Thread Sealant

— WARRANTY / PARTS / SERVICE

Workhorse products are warranted for one year from the date of purchase against manufacture or workmanship defects for personal or homeowner usage with proof of purchase. Workhorse products are warranted for 90 days for commercial users. Any unauthorized modification of a Workhorse brand sprayer will void warranty.

Your authorized dealer is the best source of replacement parts & service. To obtain prompt, efficient service, always remember to give the following information:

1. Correct part description and part number.
2. Model number of your sprayer.

Part description and part numbers can be obtained from the illustrated parts list section of this manual.

Whenever you need parts or repair service, contact your distributor /dealer first. For warranty work always take your original sales slip, or other evidence of purchase date, to your distributor / dealer.

— OPERATION

This sprayer is designed to be attached to an ATV rack or other stable surface. The pumping system draws solution from the tank, through the strainer and to the pump. The pump forces the solution under pressure to the spray wand and spray boom. The pump has a pressure switch which will shut the pump off when it reaches 60 PSI. Pressure may be regulated by opening or closing the bypass valve located on the top of the tank. Also, the boom can be cycled on and off with this valve. See the illustration in this manual for more details on using the bypass valve.

Regularly inspect the suction supply screen on the inside of the tank. Flush with water to clear any accumulated debris.

— CALIBRATION

Chemical labels may show application rates in gallons per acre, gallons per 1000 square feet or gallons per 100 square feet. You will note that the tip chart shows all three of these rating systems. Once you know how much you are going to spray then determine (from the tip chart) the spraying pressure (PSI), and the spraying speed (MPH). Conditions of weather and terrain must be considered when setting the sprayer. Do not spray on windy days. Protective clothing must be worn in some cases. **Be sure to read the chemical label carefully.** Determining the proper speed of the tractor can be done by marking off 100, 200 and 300 feet. The speed chart indicates the number of seconds it takes to travel the distances. Set the throttle and with a running start travel the distances. Adjust the throttle until you travel the distances in the number of seconds indicated by the speed chart. Once you have reached the throttle setting needed, mark the throttle location so you can stop and go again (returning to the same speed). Add water and proper amount of chemical to tank and drive to the starting place for spraying. When you are ready to spray, turn the boom valve to the "on" position. This will start solution spraying from the tips once the pump is turned on. The pressure will decrease slightly when the boom is spraying.

WARNING: Some chemicals will damage the pump valves if allowed to soak untreated for a long period of time. Always flush the pump with water after use. Do not allow chemicals to sit in pump for extended times of idleness. Follow chemical manufacturers instructions on disposal of all waste water from the sprayer.

WARNING: This product can expose you to chemicals including lead, which is known to the State of California to cause cancer. www.P65Warnings.ca.gov

— AFTER SPRAYING

After use, fill the sprayer part way with water. Start the sprayer and allow clear water to be pumped through the plumbing system and out through the spray wand and boom. Refill the tank about half full with plain water and use a chemical neutralizer such as Nutra-Sol® or equivalent and repeat cleaning instructions. Flush the entire sprayer with the neutralizing agent. Follow the chemical manufacturer's disposal instructions of all wash or rinsing water.

— WINTER STORAGE

Drain all water and chemical out of sprayer, paying special attention to pump and valves. These items are especially prone to damage from chemicals and freezing weather. The sprayer should be winterized before storage by pumping a solution of RV antifreeze through the entire plumbing. Proper care and maintenance will prolong the life of the sprayer.

RATE CHART FOR 80/110-02 SPRAY TIP

Pressure (PSI)	Capacity (GPM)	GALLONS PER ACRE BASED ON WATER - 20" SPACING							
		1 MPH 88 FPM	2 MPH 176 FPM	3 MPH 264 FPM	4 MPH 352 FPM	5 MPH 440 FPM	7.5 MPH 660 FPM	10 MPH 880 FPM	
20.0	0.14	41.8	20.9	14.0	10.5	8.4	5.6	4.2	
30.0	0.17	51.2	25.6	17.2	12.9	10.3	6.9	5.1	
40.0	0.20	59.2	29.6	19.8	14.9	11.9	7.9	5.9	
50.0	0.23	66.4	33.2	22.2	16.6	13.3	8.8	6.6	

Pressure (PSI)	Capacity (GPM)	GALLONS PER 1000 SQ. FT. BASED ON WATER - 20" SPACING							
		.96	.48	.32	.24	.19	.13	.10	
20.0	0.14	.96	.48	.32	.24	.19	.13	.10	
30.0	0.17	1.18	.59	.39	.30	.24	.16	.12	
40.0	0.20	1.36	.68	.45	.34	.27	.18	.14	
50.0	0.23	1.52	.76	.51	.38	.31	.20	.15	

Pressure (PSI)	Capacity (GPM)	GALLONS PER 100 SQ. FT. BASED ON WATER - 20" SPACING							
		.096	.048	.032	.024	.019	.012	.009	
20.0	0.14	.096	.048	.032	.024	.019	.012	.009	
30.0	0.17	.117	.059	.039	.029	.024	.015	.011	
40.0	0.20	.135	.066	.045	.034	.027	.018	.013	
50.0	0.23	.152	.076	.050	.038	.030	.020	.015	

MPH- Miles Per Hour • FPM- Feet Per Minute • PSI- Pounds Per Square Inch • GPM- Gallons Per Minute

— BOOMLESS NOZZLE RATE CHART —

SPEED IN MPH (Miles Per Hour)	Time Required in Seconds to Travel a distance of:		
	100 ft	200 ft	300 ft
1.0	68.0	136	205
2.0	34.0	68	102
3.0	23.0	45	68
4.0	17.0	34	51
5.0	14.0	27	41
6.0	11.0	23	34
7.0	9.7	19	29

1200PS	(1/4" MNPT)			SPEED (MPH)						
	PSI	GPM	SPRAY DISTANCE	1	2	3	4	5	6	7
				GALLONS PER ACRE						
20	1.0	14 ft.	35	18	12	9	7	6	5	
30	1.2	14 ft.	42	21	14	10	8	7	6	
40	1.4	14 ft.	49.5	25	16.5	12	10	8	7	

Models: LG 405 DTS, LG 407 DTS, LG 607 DTS

Assembly Instructions

1.0 --Assemble tank and trailer frame as illustrated on this page using hardware shown.

Note the orientation of the Frame Member items as their orientation is essential for proper assembly.
DO NOT OVER TIGHTEN BOLTS.

PARTS LIST		
ITEM	QTY	DESCRIPTION
1	1	40 Gallon Tank
2	1	60 Gallon Tank
3	1	Cross Member
4	1	Trailer Pan
5	1	Trailer Hitch Arm
6	1	Front Support
7	2	Boom Bracket
8	1	Hitch
9	1	Hitch Bracket
10	1	Trailer Hitch Pin
11	4	5/16 Washer
12	10	5/16-18 Hex Lock Nut
13	2	5/16-18 x .875 Hex Bolts
14	2	5/16-18 x 1.75 Hex Bolt
15	4	5/16-18 x 3.75 Hex Bolts
16	2	5/16-18 x 2.75 Hex Bolts
17	2	1/2- 13 Hex Lock Nut
18	2	1/2-13 x 2.75 Hex Bolts
19	1	Reinforcing Strap Right
20	1	Reinforcing Strap Left

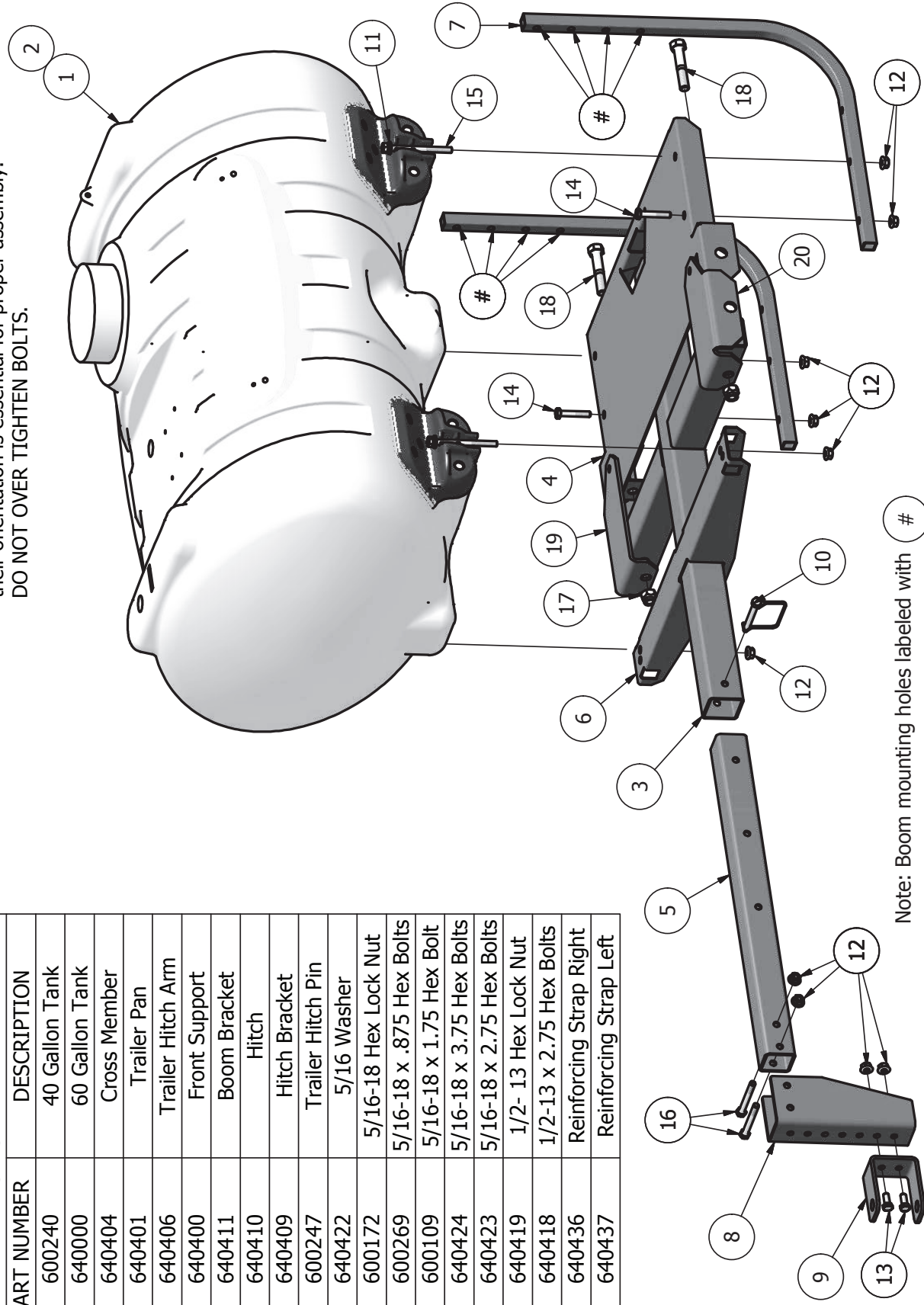

Note: Boom mounting holes labeled with #

Models: LG 405 DTS, LG 407 DTS, LG 607 DTS

cont...

Assembly Instructions

- 2.0 --Install Hose Wrap Bracket (Item 9) onto frame using 5/16 nut. 5/16 nut already installed on frame, it will need to be removed and reinstalled with the Hose Wrap Bracket.
- 2.1 --Install Axle (Item 10) through Rear Trailer Pan and Cross Member as shown, install the 15" Wheel Assemblies over Axle and secure with 1/8" Cotter Pins.
- 2.2 --Insert Lead Wire Assembly (Item 13) into plug at rear of the Pump.
- 2.3 --Join the red wire of the two wire cable to a +12V Source such as a switch, ammeter, or positive battery post. The black wire should be grounded or connected to the negative battery post.
- 2.4 --An additional lead is supplied with Lead Wire Assembly that will allow the use of a standard 12V receptacle on the vehicle. This can be used as a alternate to the battery clips.

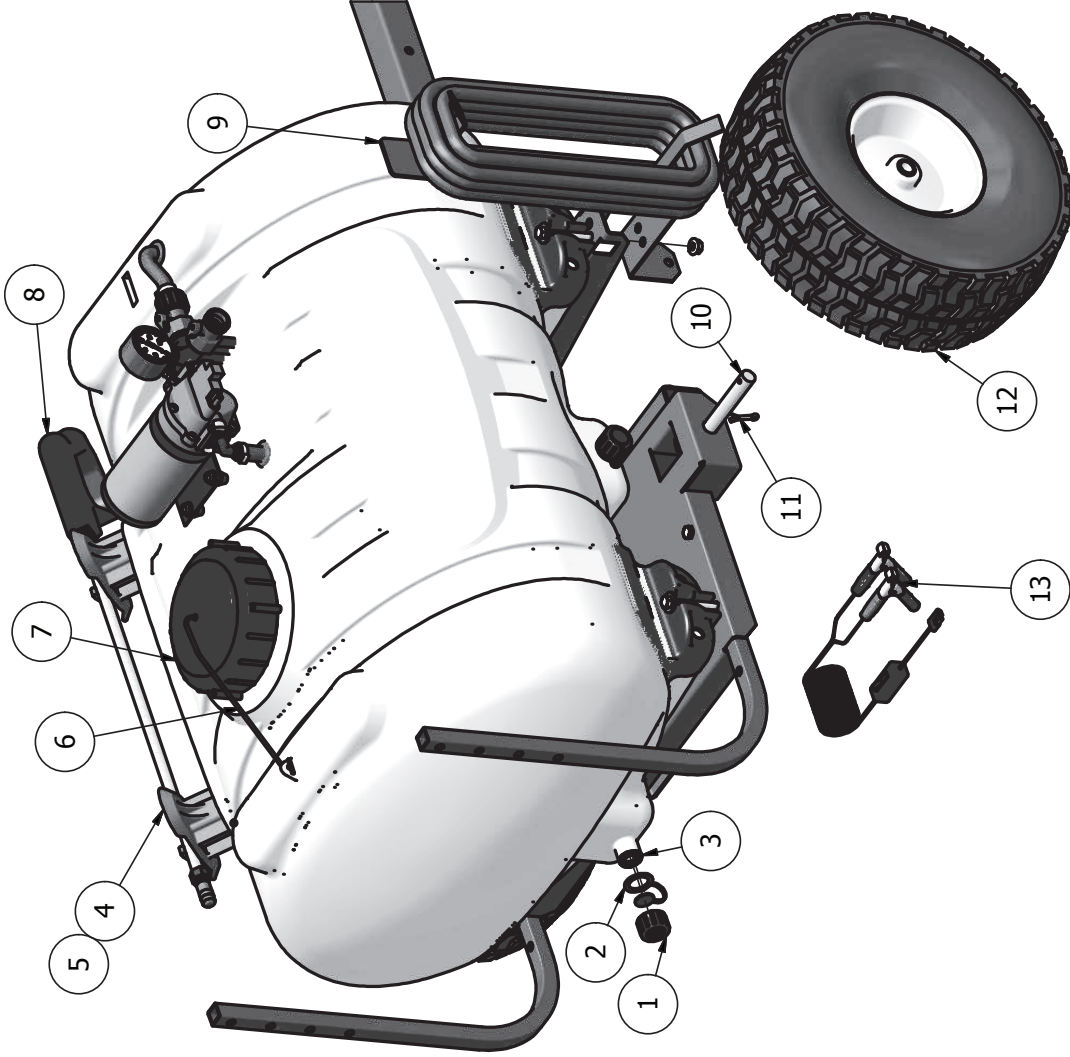

PARTS LIST		
ITEM	QTY	PART NUMBER DESCRIPTION
1	2	600139 B 3400 P
2	2	600268 Tank Drain Cap Tether
3	2	600124 W 406
4	2	600279 Plastic Hose Wrap
5	2	600152 Wand Clip Screws
6	1	600134 Tank Lid Tether
7	1	600133 Tank Lid
8	1	600147 18" Deluxe Spray Wand
9	1	640407 Hose Wrap Bracket
10	1	640405 5/8 Axle
11	2	600108 1/8 Cotter Pin
12	2	640104 15" Wheel
13	1	600270 Lead Wire Assembly with Switch (96")

Models: UTL 401, UTL 402, UTL 405, UTL 407, UTL 408, UTL 40 BL, UTL 601, UTL 602, UTL 607, UTL 608, UTL 60 BL

PARTS LIST			
ITEM	QTY	PART NUMBER	DESCRIPTION
1	1	600240	40 Gallon Tank
2	1	640000	60 Gallon Tank
3	2	640402	Side Panel
4	2	640400	Front Support
5	2	640411	Boom Bracket
6	4	640422	5/16 Washer
7	4	600172	5/16-18 UNC Hex Nut
8	4	640424	5/16-18 UNC x 3.75 Hex Bolt

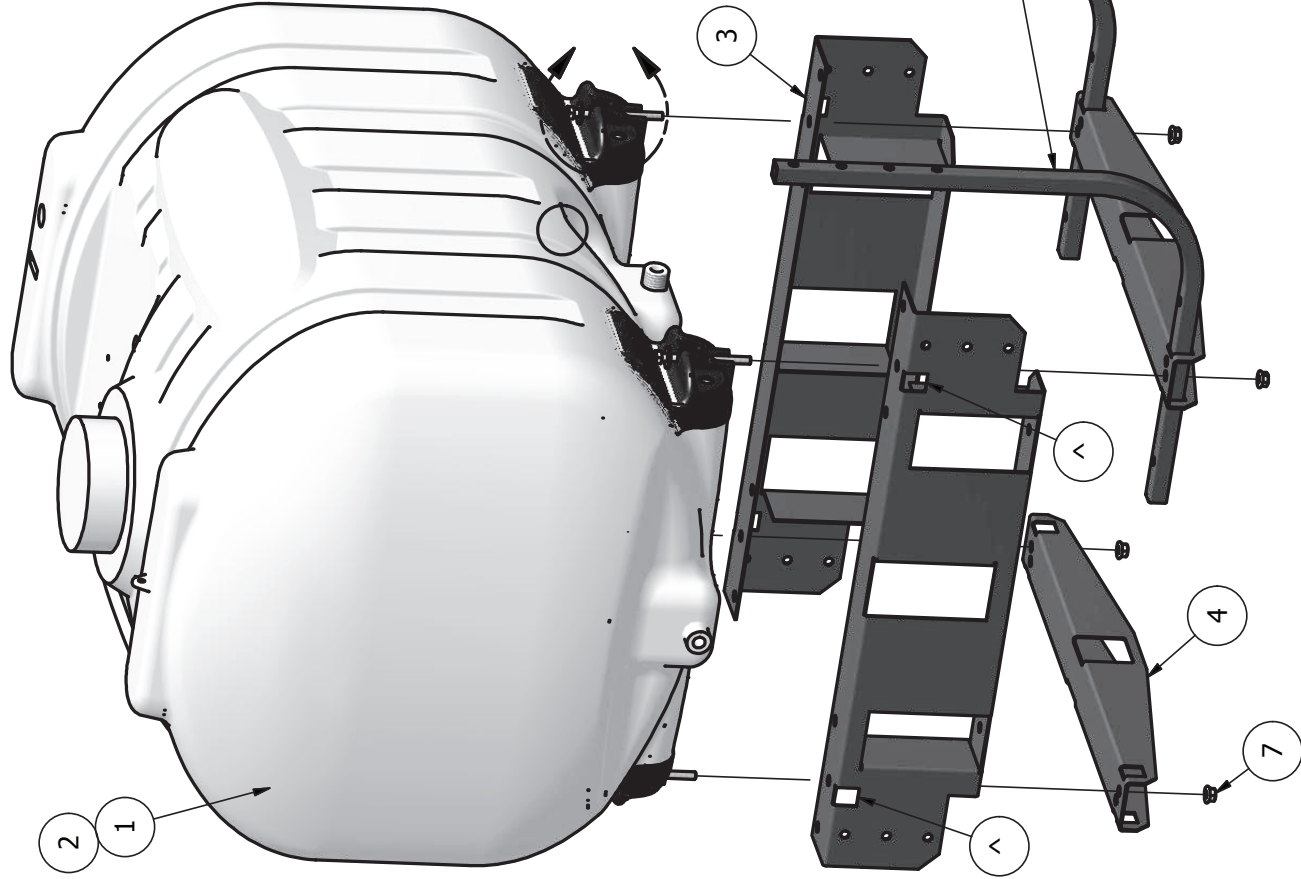

Assembly Instructions

1.0 --Assemble tank and frame as illustrated on this page using hardware shown. Note the orientation of the Frame Member items as their orientation is essential for proper assembly. DO NOT OVER TIGHTEN BOLTS.

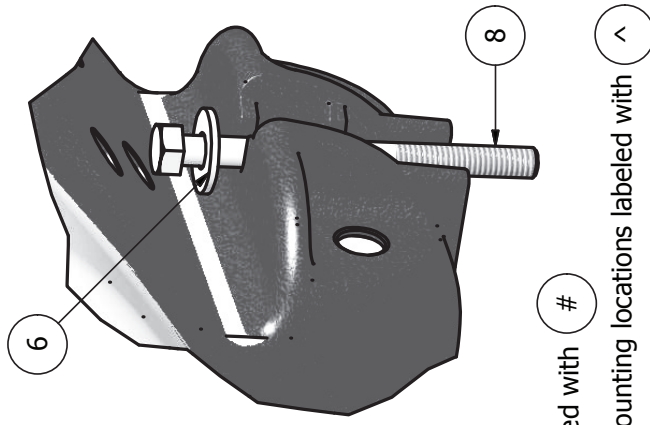

Note: Boom mounting holes labeled with #

Note: Secondary Boom Bracket mounting locations labeled with ^

Assembly Instructions

- 2.0 --Install Hose Wrap Bracket (item 9) onto frame using 5/16 screws (item 10) and nuts (item 11)
- 2.1 --Insert Lead Wire Assembly (Item 12) into plug at rear of the pump
- 2.2 --Join the red wire of the two wire cable to a +12V Source such as a switch, ammeter, or positive battery post. The black wire should be grounded or connected to the negative battery post.
- 2.3 --An additional lead is supplied with Lead Wire Assembly that will allow the use of a standard 12V receptacle on the vehicle. This can be used as a alternate to the battery clips

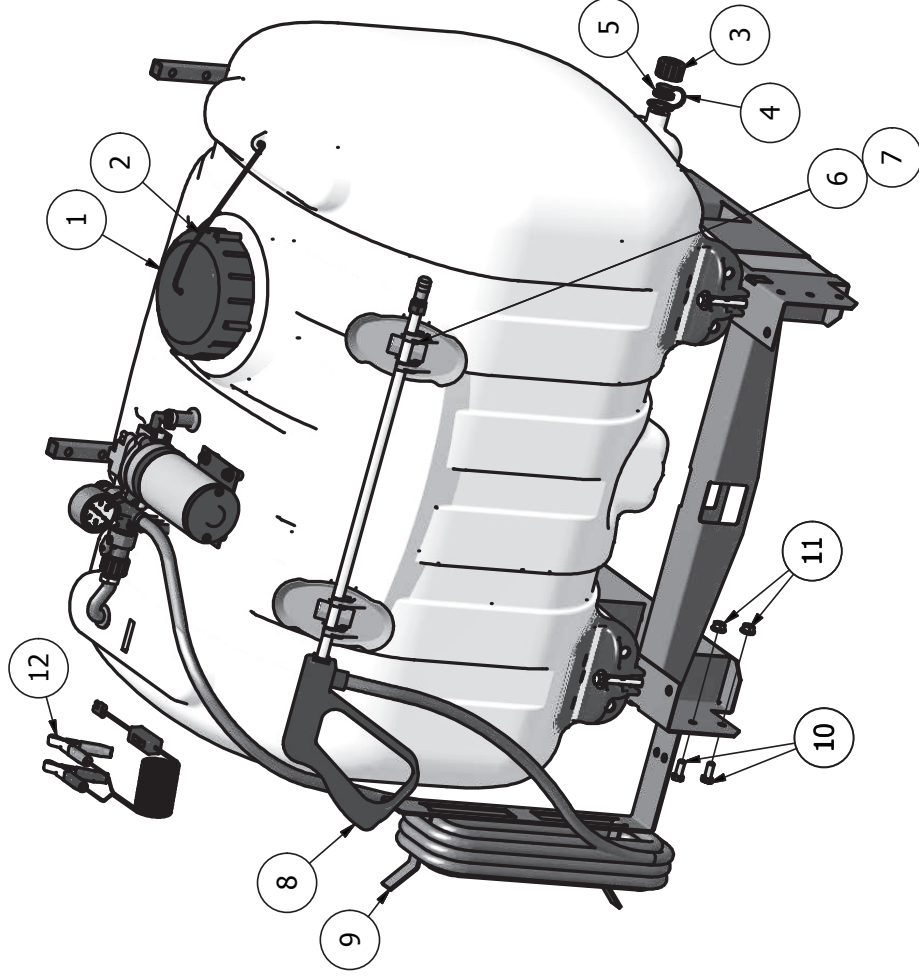

PARTS LIST			
ITEM	QTY	PART NUMBER	DESCRIPTION
1	1	600133	Tank Lid
2	1	600134	Tank Lid Tether
3	4	600139	B 3400 P
4	2	600268	Tank Drain Cap Tether
5	4	600124	W 406
6	2	600279	Plastic Hose Wrap
7	2	600152	Wand Clip Screw
8	1	600147	18" Deluxe Spray Wand
9	1	640407	Hose Wrap Bracket
10	2	600269	5/16-18 x .875" UNC Hex Bolt
11	2	600172	5/16-18 UNC Lock Nut
12	2	600270	Lead Wire Assembly with Switch (96")

Boom Assembly

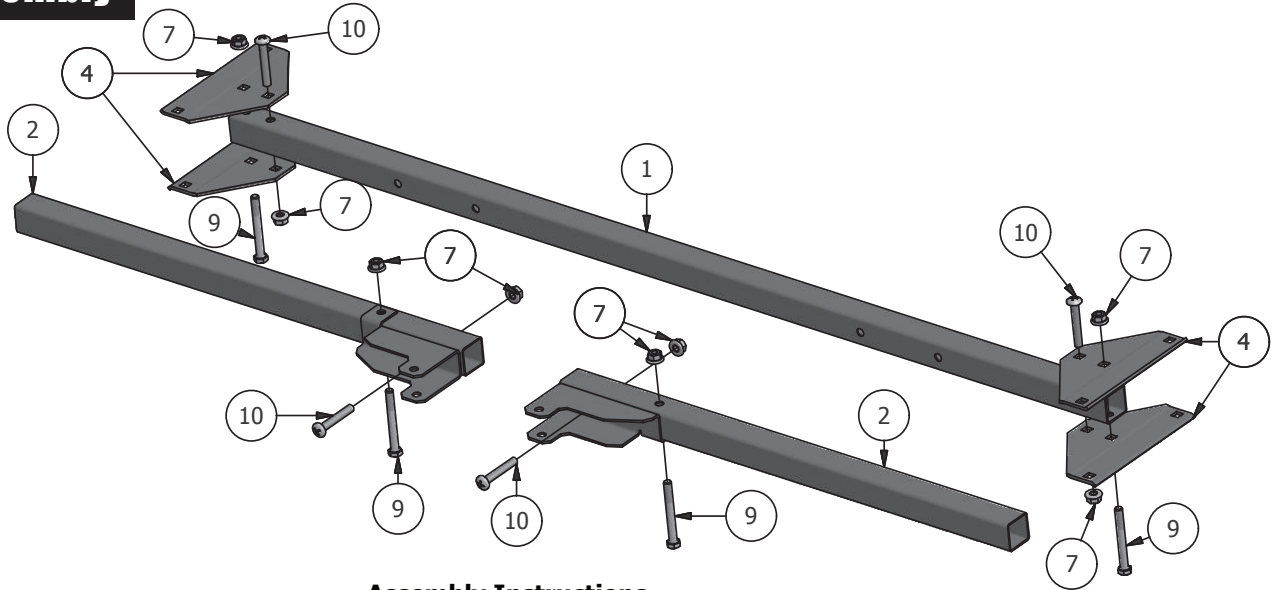

Assembly Instructions

- 1.0--Install Boom Arm Brackets to Boom End Sections (23" End Sections for 5 Nozzle and 38" End Sections for 7 Nozzle) using 5/16 x 2.75" Hex Bolts, 5/16 x 2" Pan Head Screws, and 5/16 Hex Nuts. Note the orientation and position of these parts as it is essential for proper assembly.
- 1.1--Install (2) Boom Center Brackets to each end of the 45" Center Boom Section using 5/16 x 2" Pan Head Screws as shown.
- 1.2--Install the Boom Hinge Bolts (5/16 x 2" Pan Head Screws) Through the Boom Center Brackets and the Boom End Brackets as shown in the close up detailed view. Secure in place with the 5/16 Lock Nuts. Making sure not to overtighten bolts so boom can rotate freely.
- 1.3--Install the Boom Springs to Boom Center Brackets and 5/16 x 2.75 Hex bolts as shown in the close up detailed view.
- 1.4--Install the 5/16 Lock Nuts onto 2.75" Hex Bolts to secure the Boom Springs in place. As shown in close up detailed view.
- 1.5--Install the now completed Boom Assembly to the Square Boom Brackets of the Frame Assembly at the desired height, using 5/16 x 2.75" Hex Bolts and 5/16 nuts.

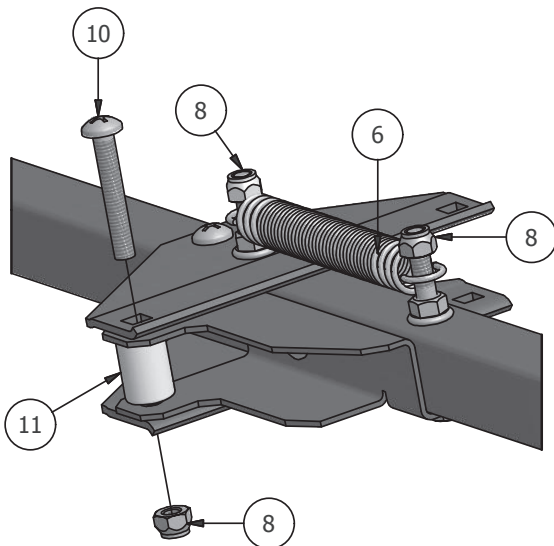
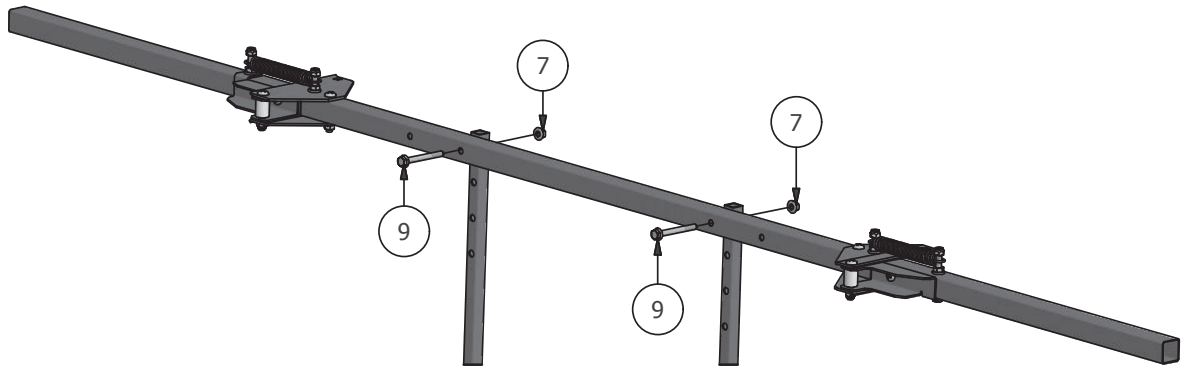

PARTS LIST

ITEM	QTY	PART NUMBER	DESCRIPTION
1	1	640414	45" Boom Center Section
2	2	640412	23" Boom End Section
3	4	640413	48" Boom End Section
4	4	640416	Boom Center Bracket
5	2	640417	Boom Arm Bracket
6	4	640428	Boom Spring
7	8	600172	5/16-18 UNC Nut
8	6	620106	5/16-18 UNC Lock Nut
9	6	640423	5/16-18 UNC x 2.75" Hex Bolt
10	6	640426	5/16-18 UNC x 2" Pan Head Screw
11	2	640459	Boom Spacer

Boom Assembly

cont...

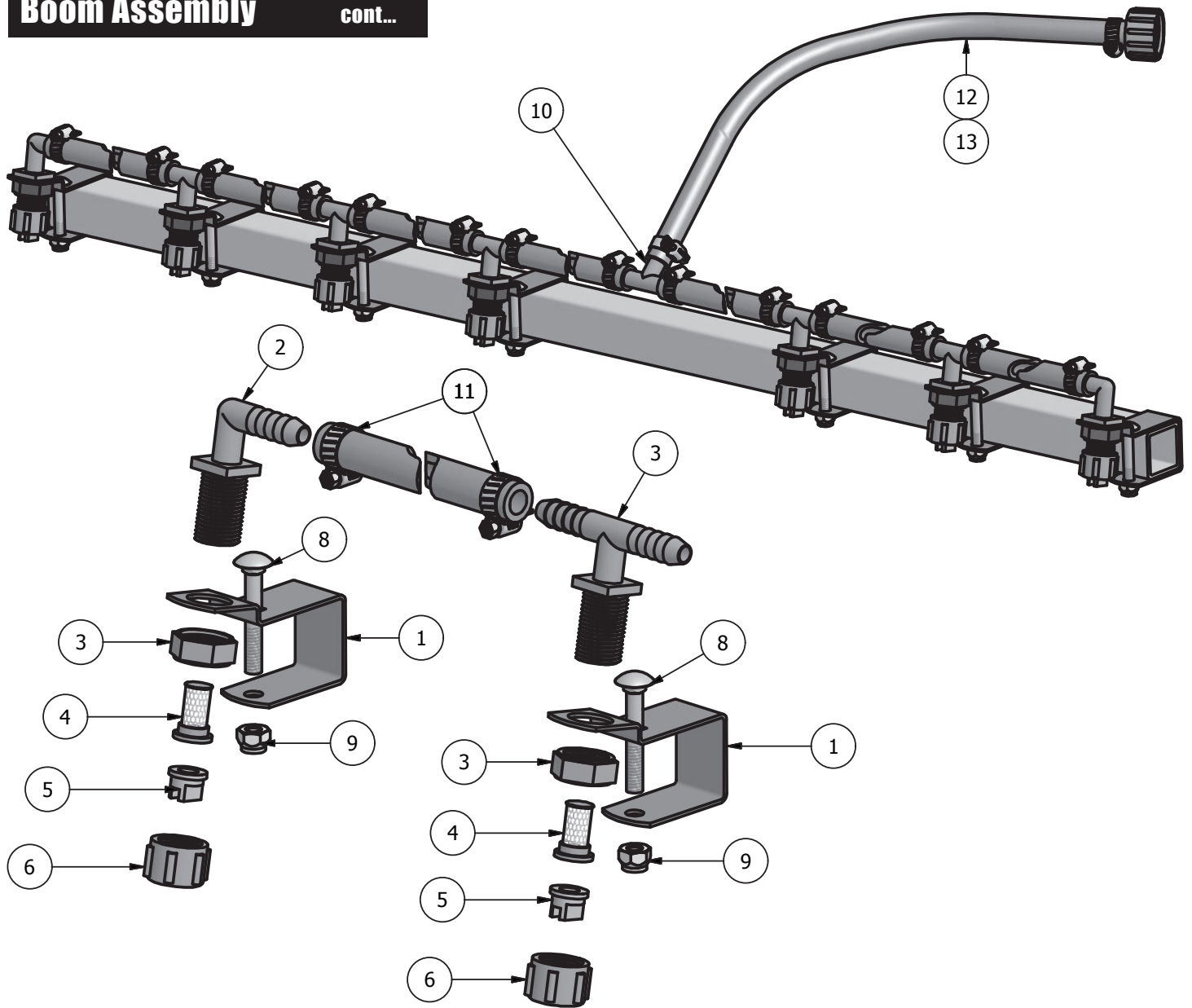

Assembly Instructions

2.0--Install Boom Clamps onto the Spray Boom Assembly using 1/4" x 1.75" bolts and 1/4" Lock Nuts. Note: Boom Clamps should be space 20" apart.

2.1-- Install Nozzle Body Fittings in Boom Clamps and secure in place with N1116 P Nuts.

2.2--Insert Check Valves into Nozzle Body Fittings.

2.3--Insert Spray Tip into 8027 P Nuts and screw onto Nozzle Body fittings.

2.4--Install Hose Assembly onto inline valve on the Pump Manifold.

PARTS LIST

ITEM	5 Nozzle QTY	7 Nozzle QTY	PART NUMBER	DESCRIPTION
1	5	7	640415	Boom Clamp
2	2	2	600112	NTL38 P Fitting
3	3	5	620112	NTT 38 P Fitting
4	5	7	600116	N1116 P Nut
5	5	7	600117	Check Valve / Strainer
6	5	7	640432	Flat Fan Spray Tip
7	5	7	600119	8027 P Nut
8	5	7	640427	1/4-20 x 1.75" Bolt
9	5	7	600107	1/4-20 Lock Nut
10	1	1	600142	T38 P Fitting
11	12	16	600120	5/8" Hose Clamp
12	1	0	640434	5 Nozzle Hose Assembly
13	0	1	640435	7 Nozzle Hose Assembly

Boomless Assembly

PARTS LIST		
ITEM	QTY	DESCRIPTION
1	1	Boomless Manifold Assembly
2	1	Boomless Bracket
3	2	Boom Bracket
4	2	Bonnet Cap
5	1	1200 PSL Tip (Left)
6	1	1200 PSL Tip (Right)
7	4	5/16" x 1.25 Hex Bolt
8	8	5/16" Hex Nut
9	1	Boomless Hose Assembly

Boomless Assembly Instructions

- 1.0--Install Boomless Bracket onto Square Boom Brackets using 5/16" bolts and 5/16" nut
 - 1.1--Slide Quick Clip into the back of the Boomless Manifold Assembly. (Quick Clip can only be installed while the Boomless Manifold is not installed on the Boomless Bracket and is used to secure the hose to the Manifold)
 - 1.2--Install Boomless Manifold Assembly onto the Boomless Bracket using 5/16" bolts and 5/16" nuts
 - 1.3--Install Bonnet Caps onto both ends of the Boomless Manifold Assembly.
 - 1.4--Using a quality thread tape install the Left Boomless Tip onto the Left Bonnet Cap and the Right Boomless Tip onto the Right Bonnet Cap. Making sure both are oriented correctly to achieve the correct spray pattern. **DO NOT OVERTIGHTEN.**
 - 1.5--Install Boomless Hose Assembly to Boomless Manifold and secure with Quick Clip.
- Then Install the other end to Pump Manifold.

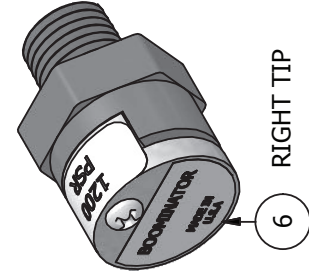
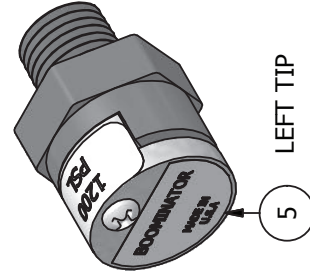
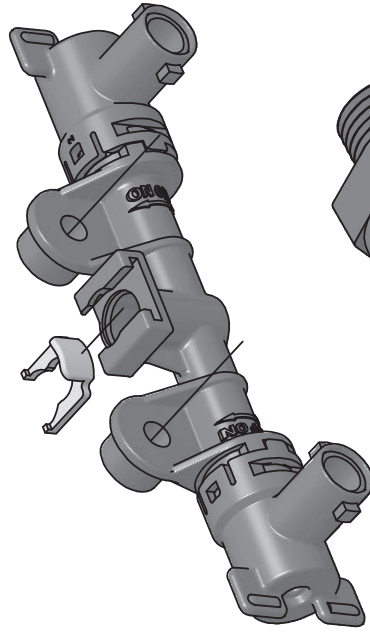
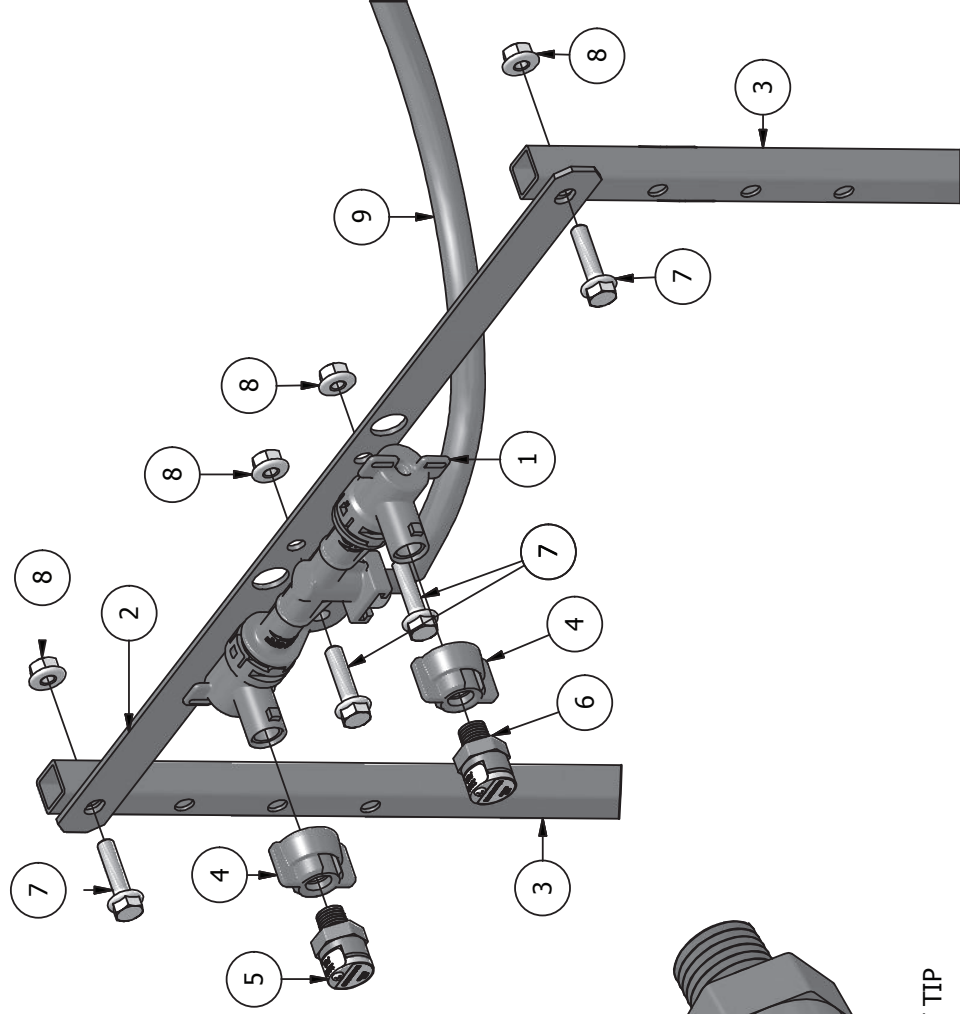

Pump & Valve Assembly

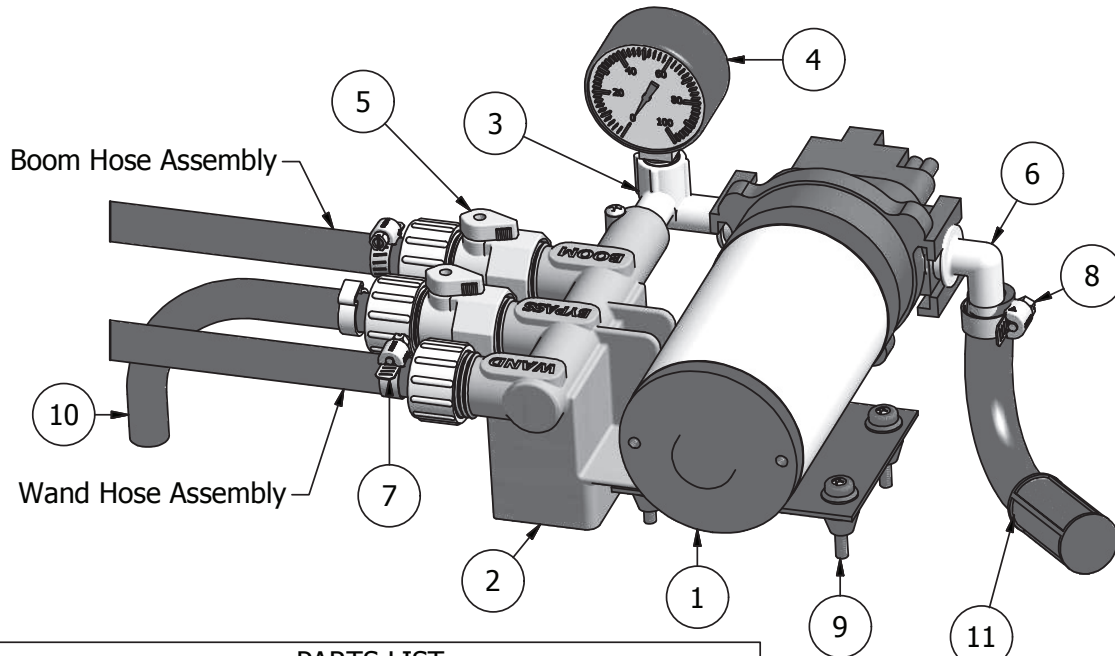

PARTS LIST			
ITEM	QTY	PART NUMBER	DESCRIPTION
1	1	640451	2.2 GPM Pump*
1	1	630201	4.0 GPM Pump*
1	1	630031	5.0 GPM Pump*
2	1	600289	Manifold Body
3	1	600291	Elbow (2.2 pumps)
3	1	600292	Elbow (4.0 & 5.0 pumps)
4	1	600129	Gauge 0-100 PSI
5	2	600216	Inline Valve
6	1	600287	QD EL 12
7	2	600120	5/8" Hose Clamp
8	1	600288	1/2" Hose Clamp
9	4	600130	10-24 x 1.25 Screw
10	1	600213	Relief Hose Assembly
11	3	600315	Suction Hose Assembly
12	1	600298	Cap Assembly (not shown)

*Pump included depends upon model purchased.

Install Wand Hose Assembly onto Swivel Barb Assembly, by placing a Hose Clamp over the open end of the hose on the Wand Hose Assembly. Then pressing the open end of the hose onto the Swivel Barb Assembly like shown. Secure in place by tightening the Hose Clamp as shown.

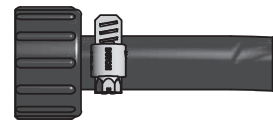
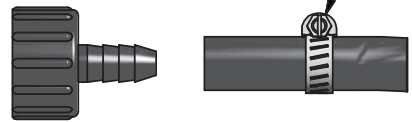

The Lever adjusts the system pressure by relieving liquid back to the tank. Adjusting this lever will increase or decrease pressure to both the spray wand and the spray boom.

The lever turns the spray boom on and off

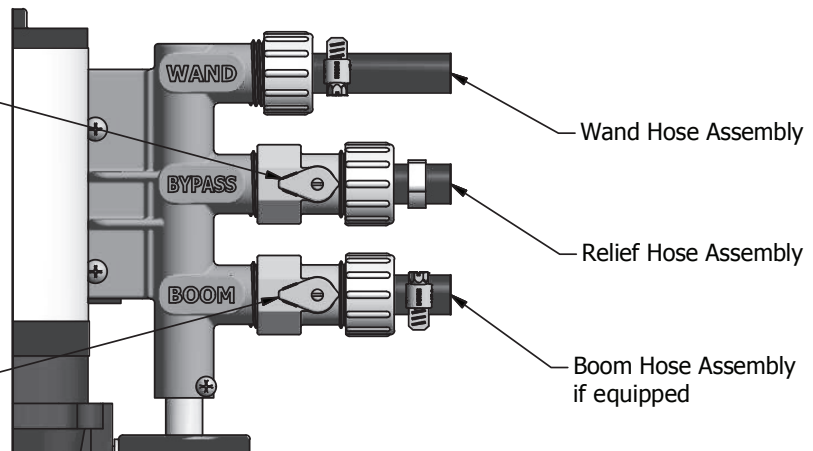

PowerFLO™ Series Pumps

12 Volt DC Motor-Driven Diaphragm Pumps



Model: 7802: 2.2 GPM



Model: 5900: 4.0 GPM

Specifications —

Motor:

Type: 12 VDC, permanent magnet, totally enclosed, non-ventilated

Leads: 18 AWG, 12" long

Duty Cycle: See Heat Rise graph

Temperature Limits: Motor is not equipped with thermal protection. For user safety, optimal performance, and maximum motor life, the motor surface temperature should not exceed 150°F (66°C) (see Heat Rise graph above right).

Pump:

Type: 3 chamber positive displacement diaphragm pump, self priming, capable of being run dry, demand or bypass model.

Certifications: NSF Standard 58

Liquid Temperature: 140°F (60°C) Max.

Priming Capabilities: 14 feet (4 m)

Max Pressure: 60 PSI

Inlet/Outlet Ports: 7802: Quick Attach

Materials of Construction:

Housing: Polypropylene Diaphragm: Santoprene

Valves: Viton Fasteners: Stainless steel

Weight: 6 lbs (2.7 kg)

Installation and Operation Precautions —

1. The pump is equipped with a pressure sensing demand switch that controls the maximum operating pressure.
2. In addition, never subject the pump to pressures above 125 PSI (8.5 bars).
3. As long as there is inlet water pressure, the pump will not stop forward flow of water even if the motor is turned off. Be sure the system has positive means of shutting off water supply.
4. Do not operate pump in an explosive environment. Arcing from the motor brushes, switch or excessive heat from an improperly cycled motor may cause an explosion.
5. Do not locate the pump motor near low temperature plastics or combustible material. The surface temperature of the motor may exceed 250°F (120°C).
6. Do not pump gasoline or other flammable liquids. Pump head materials are designed for use with water only. Do not use with petroleum products.
7. Do not assume fluid compatibility. If the fluid is improperly matched to the pumps' elastomers, a leak may occur.
8. To prevent electrical shock, disconnect power before initiating any work. In the case of pump failure, the motor housing and/or pump fluid may carry high voltage to components normally considered safe. Therefore, always consider electrical shock hazard when working with and handling electrical equipment. If uncertain, consult an electrician. Electrical wiring should only be done by a qualified electrician per local and state electrical codes.

Specifications —

Motor:

Type: 12 VDC, permanent magnet, totally enclosed, non-ventilated

Leads: 14 AWG, 12" long

Duty Cycle: See Heat Rise graph

Temperature Limits: Motor is not equipped with thermal protection. For user safety, optimal performance, and maximum motor life, the motor surface temperature should not exceed 180°F (82°C) (see Heat Rise graph above right).

Pump:

Type: 5 chamber positive displacement diaphragm pump, self priming, capable of being run dry, demand or bypass mode.

Certifications: NSF Standard 58

Liquid Temperature: 140°F (60°C) Max.

Priming Capabilities: 14 feet (4 m)

Max Pressure: 60 PSI

Inlet/Outlet Ports: 5900: Quick Attach

Materials of Construction:

Housing: Polypropylene Diaphragm: Santoprene

Valves: Viton Fasteners: Stainless steel & Zinc plated

Weight: 6 lbs (2.7 kg)

Recommendations —

Electrical:

1. The PowerFlo™ series pumps are designed for intermittent duty. Make sure that "OFF" periods are sufficient. Refer to Rapid ON/OFF Operation. Consult the factory for particular data and design criteria.
2. Be sure power supply used is adequate for the application.
3. Pump and motor specifications are based on an alternator charged battery (13.7 VDC)
4. Use sufficient battery supply power. UTV and lawn tractor batteries may affect pump performance due to low voltage and amp ratings.

Servicing —

Every Year: Check system against operating standards.

Every 2-3 Years: We recommend replacing the diaphragm and checking against operating standards.

* Important return safety instructions:

When you return your pump for warranty or repair, you must always do the following:

1. Flush chemical residue from the pump (best done in the field).
2. Tag pump with type of chemicals having been sprayed.
3. Include complete description of operation problem, such as how pump was used, symptoms of malfunction, etc. Since pumps can contain residues of toxic chemicals these steps are necessary to protect all the people who handle return shipments, and to help pinpoint the reason for the breakdown.

Troubleshooting Guide —

Problem/Causes and Remedies:

Pump will not Start

Check:

- Correct voltage ($\pm 10\%$) and electrical connections
- Fuse or breaker
- Pressure switch operation and correct voltage at switch
- Rectifier or motor for open or grounded circuit
- Locked drive assembly

Pump will not Shut Off (Output line closed and no leaks)

Check:

- Air trapped in outlet line or pump head
- Correct voltage to pump
- Debris in pump inlet/outlet valves
- Loose drive assembly or pump head screws
- Pressure switch operations/adjustments

Pump will not Prime (No discharge with motor running)

Check:

- Debris in strainer
- Restriction (kinks) in inlet/outlet tubes
- Debris or swelling in inlet/outlet valves

Leaks from Pump Head or Switch

Check:

- Loose screws at switch or pump head
- Switch diaphragm ruptured or pinched
- Punctured diaphragm if fluid is present

Spray & Pump FAQs —

--Why does the pump not run all the time?

This is a demand pump and only runs with flow; spray wand, by-pass, spray tips or leak in system

--Why does the pump surge while using the spray wand?

Low flow may cause the pump to surge (or cycle). This could happen when the spray wand is adjusted for a small or fine spray pattern. To overcome, slightly open the by-pass valve.

--How do I adjust the pressure?

Pressure should be adjusted by regulating the by-pass valve (slightly opening or closing).

--What is the optimal operating pressure?

40 PSI - This can be accomplished by turning on the pump and adjusting the bypass valve until the gauge reads 40 PSI (or slightly higher). The pump will run continuously. Ensure that the boom and/or handgun is not spraying while you set the pressure. The pressure will drop slightly when the boom and/or handgun is operated.

--What pressure should the pressure gauge read?

Please refer to the operation instructions for boom operating pressures, varying boom pressures can be achieved by regulating or adjusting the by-pass valve. Typically the spray wand will be operated between 20 and 40 PSI.

--What is the recommended PSI to inflate the tires?

30 PSI Max

--My pump quit and will not restart - what should I check?

Check all electrical connections. Ensure switch is in the on position. Check in-line fuse and/or fuse in car adapter end. Ensure correct voltage $\pm 10\%$. 12-13 volt

--Low flow or no flow at all - what should I check?

Check for a clogged suction hose and/or suction strainer. Often you will need to clean the suction strainer. Check for proper voltage.

--Is there a fuse for the sprayer?

Yes, either an in-line fuse, a fuse located in the car adapter housing or both.

--What size fuse should I use as a replacement?

7.5 amp

--What is the range of the spray wand?

35 feet max

--How should I clean the tank after use?

Tank should be cleaned with Nutrasol® or similar tank cleaning agent, and then rinsed with water.

--Is there an adjustment screw on the pump to adjust pressure?

Yes, please refer to the operation instructions, "Adjusting the Pressure Switch".

--How do I remove / replace fuse?

Unscrew in-line fuse connector, or unscrew the car adapter housing.

--Can the spray tip on the wand be replaced with a different type of tip?

Yes, however your wand comes with a #18 tip which is standard. Brass tips generally produce better spray patterns than plastic.

--Each time I turn on the pump my fuse blows.

1) Excessive voltage 2) Improper adjustment of the pressure switch 3) Damaged wiring harness.

--What is the warranty (time duration) on pump, tank, trailer pieces, and accessories?

1 year as stated in operation instructions.

--Pressure gauge reads 85 -90 psi before shutting off - should pump shut off at 60 psi?

Pump 7802 2.0 GPM comes preset from the factory to shut off at 60 PSI. Should this vary please see, "Adjusting the Pressure Switch" in the operation manual. Turn on pump and hold spray wand open, slowly adjust until the pump shuts off at 60 PSI.

--Pump continues to run and surge when not spraying.

Ensure the by-pass is completely closed and your system has no leaks. Check by-pass hose to ensure no fluid is passing through the valve while in the closed position. If so replace valve.

WARNING - Ensure the wiring harness does not become pinched or damaged in any way. This may damage the pump or cause the wiring harness to overheat, resulting in a melt down or fire.