

– ASSEMBLY

This unit comes fully assembled

– GENERAL INFORMATION

The purpose of this manual is to assist you in assembling, operating and maintaining your sprayer. Please read it carefully as it furnishes information which will help you achieve years of dependable trouble-free operation.

– WARRANTY / PARTS / SERVICE

Workhorse products are warranted for one year from the date of purchase against manufacture or workmanship defects for personal or homeowner usage with proof of purchase. Workhorse products are warranted for 90 days for commercial users. Any unauthorized modification of a Workhorse brand sprayer will void warranty.

Your authorized dealer is the best source of replacement parts and service. To obtain prompt, efficient service, always remember to give the following information:

1. Correct part description and part number.
2. Model number of your sprayer.

Part description and part numbers can be obtained from the illustrated parts list section of this manual.

Whenever you need parts or repair service, contact your distributor / dealer first. For warranty work always take your original sales slip, or other evidence of purchase date, to your distributor / dealer.

*** Important return safety instructions:**

When you return your pump for warranty or repair, you must always do the following:

1. Flush chemical residue from the unit
2. Tag unit with type of chemicals having been sprayed.
3. Include complete description of operation problem, such as how unit was used, symptoms of malfunction, etc.

Since unit can contain residues of toxic chemicals these steps are necessary to protect all the people who handle return shipments, and to help pinpoint the reason for the breakdown.

– BATTERY CHARGING

It is recommended to charge the battery for 8-10 hours before using, or if the battery has been stored for 6 or more months without usage. Once fully charged you should be able to spray 40 gallons of fluid, or 8 consecutive tanks.

To charge the battery...

1. Plug the charger into a 110 Volt AC electrical receptacle.
2. Insert the plug on the opposite end of the charger into the charging jack located on the back panel of the sprayer.
3. Reverse the above steps when charging is complete.

CAUTION: Never leave the charger connected to the battery for more the 20 hours, as this may damage the battery.

– OPERATION

This sprayer is designed to be pulled or pushed by hand.

Pour solution into the tank and stir to mix. For liquid chemicals it is possible to mix by spraying the handgun into the tank.

Turn the switch to the "ON" position and spray by squeezing the lever on the handgun. The unit is supplied with a demand pump that will only operate while the lever on the handgun is depressed.

Operation Precautions

1. **Do not operate pump in an explosive environment.** Arcing from the motor brushes, switch or excessive heat from an improperly cycled motor may cause an explosion.
2. **Do not pump gasoline or other flammable liquids.**
3. **Do not assume fluid compatibility.** If the fluid is improperly matched to the pumps' elastomers, a leak may occur.

– TROUBLE SHOOTING

Pump will not run:

1. Check fuse next to the power switch. If blown or damaged replace with a new 5 Amp fuse.
2. Insure the battery is fully charged
3. Check that the on/off switch is in the on position
4. Insure that strainer located on bottom of tank is free of debris.
5. Insure there are NO kinks in the inlet/outlet hoses.

– AFTER SPRAYING

After use fill the sprayer part way with water. Start the sprayer and allow clear water to be pumped through the plumbing system and out through the spray wand. Refill the tank about half full with plain water and use a chemical neutralizer such as Nutra-Sol® or equivalent and repeat cleaning instructions. Flush the entire sprayer with the neutralizing agent. Follow the chemical manufacturer's disposal instructions of all wash or rinsing water.

– WINTER STORAGE

Drain all water and chemical out of sprayer, paying special attention to pump and valves. These items are especially prone to damage from chemicals and freezing weather. The sprayer should be winterized before storage by pumping a solution of RV antifreeze through the entire plumbing. Proper care and maintenance will prolong the life of the sprayer.

 **WARNING:** This product can expose you to chemicals including lead, which is known to the State of California to cause cancer. www.P65Warnings.ca.gov

— PUMP, HOSE & BATTERY ASSEMBLY

PARTS LIST		
ITEM	QTY	DESCRIPTION
1	1	B 3400 P
2	4	Pinch Clamp
3	4	#8x3/4 TEK Screw
4	1	Back Panel
5	1	Retractable Handle Assy.
6	1	1/4" Suction Hose
7	1	Economy Wand Assembly
8	1	W 406
9	2	EL14QD
10	1	C 1400 CP
11	1	Wire Kit Assembly
12	1	Lithium Battery Pack
13	1	Foam Battery Adapter
14	1	1.0 GPM QA Pump
15	1	Lithium Ion Battery Charger

*

* - Not Shown

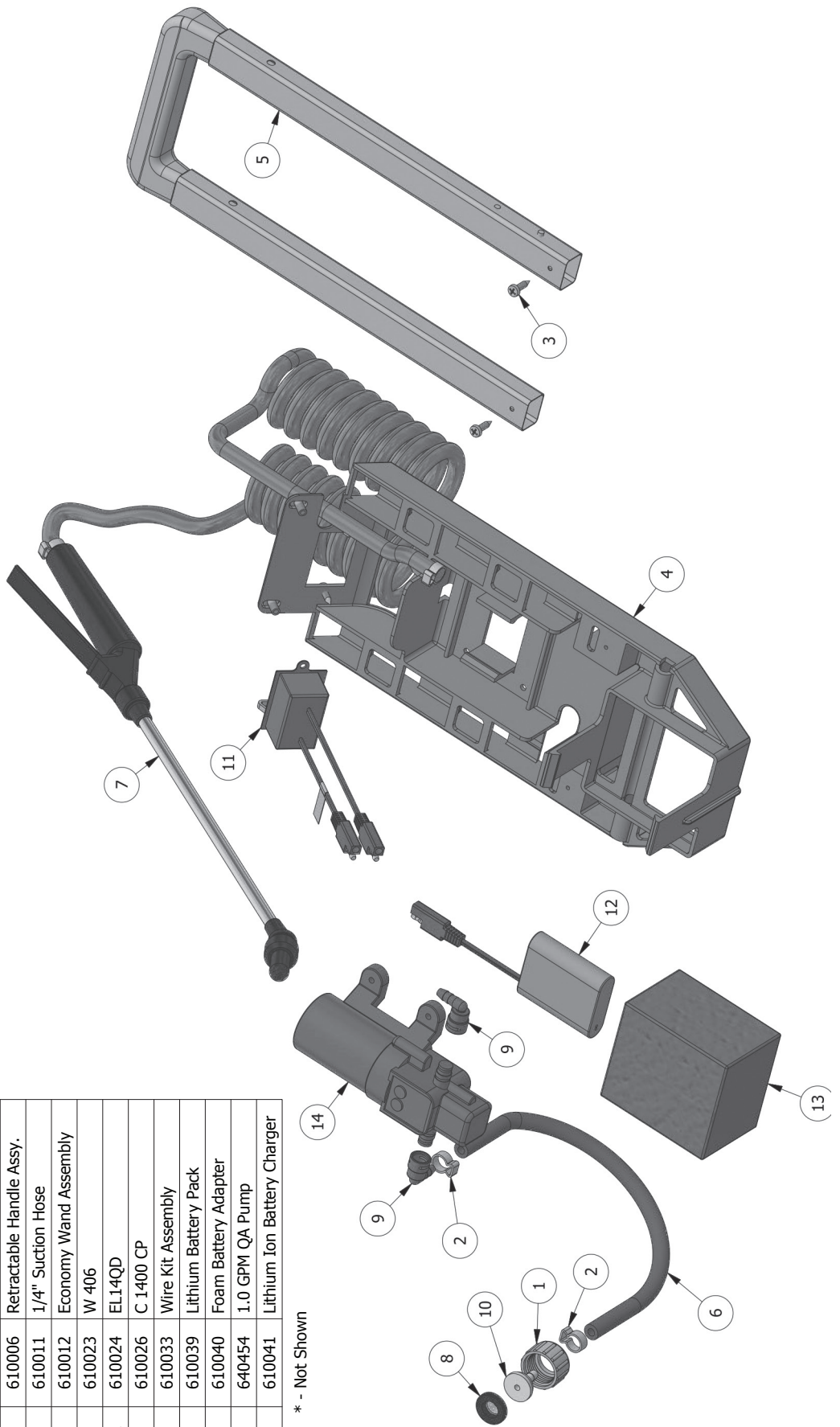

— REAR COMPARTMENT ASSEMBLY

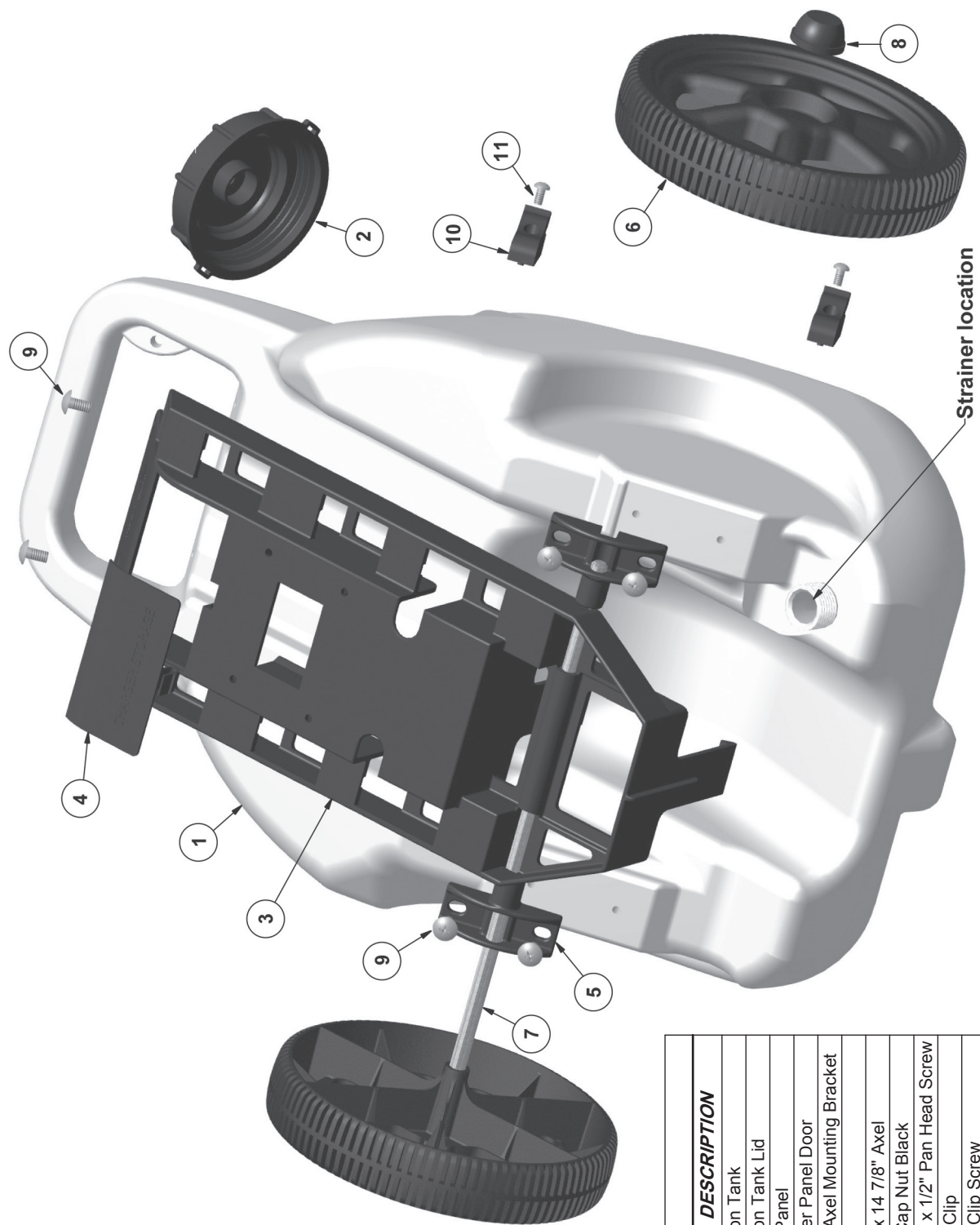

Parts List			
ITEM	QTY	PART NUMBER	DESCRIPTION
1	1	610000	5 Gallon Tank
2	1	610001	5 Gallon Tank Lid
3	1	610002	Back Panel
4	1	610003	Charger Panel Door
5	2	610005	φ3/8" Axle Mounting Bracket
6	2	610004	Wheel
7	1	610013	φ3/8" x 14 7/8" Axle
8	2	610019	φ3/8 Cap Nut Black
9	6	610017	1/4-20 x 1/2" Pan Head Screw
10	2	600151	Wand Clip
11	2	600152	Wand Clip Screw

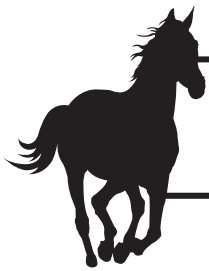

WORKHORSE

S P R A Y E R S

a Division of Green Leaf, Inc.®

Assembly / Operation Instructions / Parts

LG 05 SS



MODEL # LG 05 SS

— 5 GALLON SPOT SPRAYER —

- 5 Gallon Polyethylene Tank
- 1.0 GPM Demand Pump
- Lever Handgun
- Rechargeable 12V Battery
- AC Charger w/built in Storage Compartment
- Telescoping Handle
- Large 8 Inch Wheels
- 9 foot coil hose